

KONICA MINOLTA

PARTS GUIDE MANUAL

APRIL 2005

bizhub 180/bizhub 210

INFORMATION FOR PARTS GUIDE MANUAL

To find correct Parts No., refer to the "HOW TO MAKE THE BEST USE OF THIS MANUAL" in the following page.

HOW TO MAKE THE BEST USE OF THIS MANUAL

- 1 When you order, please check the proper figures beforehand that are on Our Parts Guide Manual, and order with the appropriate figures.
- 2 For screws, Nuts, Washers, retaining rings and Pins which are used in this model, one letter is shown on the Standard parts column of Parts list and exploded diagrams.
- 3 In order to maintain safety of the product, some specific parts composed of this product are set up as "essential safety parts".
- 4 The assigned parts number for the "essential safety parts" is indicated as "SP00-****".
When replacing these parts, follow precautions for disassembling and installing which are listed in the Service Manual.
Do not use any parts that are not set up as
- 5 ♣ means that there are exclusive parts for each destination.
Please check the appropriate destination when you order.
- 6 Revision Mark
Marked as ▲ on the illustration shows that the revision has been made.
- 7 All rights reserved. (any reprints or quotations are prohibited.)
Use of this parts guide manual should be strictly supervised to avoid disclosure of confidential information.

SYSTEM OUTLINE

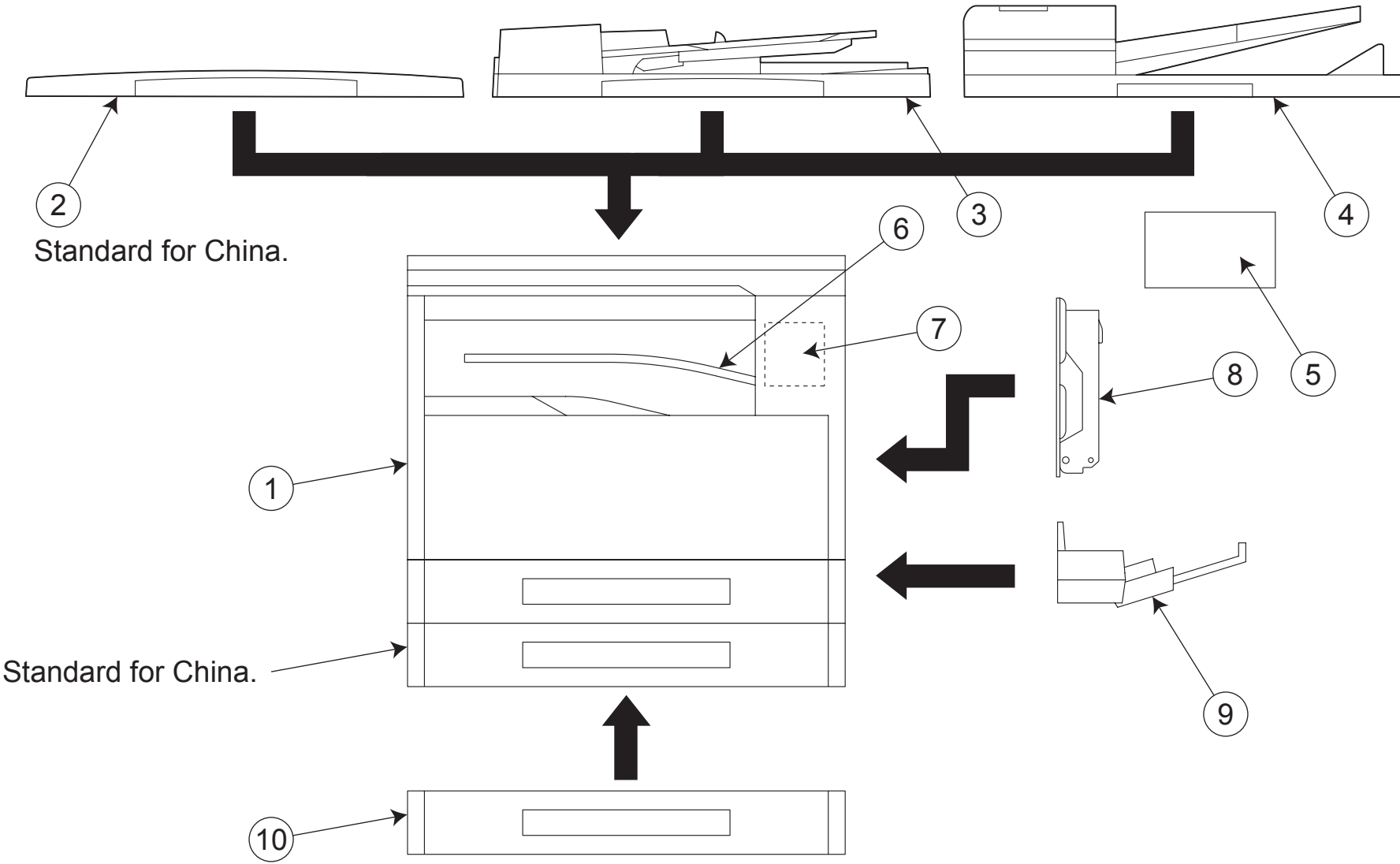

GENERAL CONTENTS

No.	Description	Model
1	DIGITAL MFP B/W	bizhub 180/bizhub 210
2	OTHER OPTION	OC-504
3	DOCUMENT FEEDER	DF-605
4	DOCUMENT FEEDER	DF-502
5	OTHER OPTION	MK-501
6	OTHER OPTION	SF-501
7	STACKER	JS-503
8	DUPLEX	AD-504
9	PAPER FEEDER	MB-501
10	PAPER FEEDER	PF-502

DIAGRAMS OF MAIN PARTS SECTION

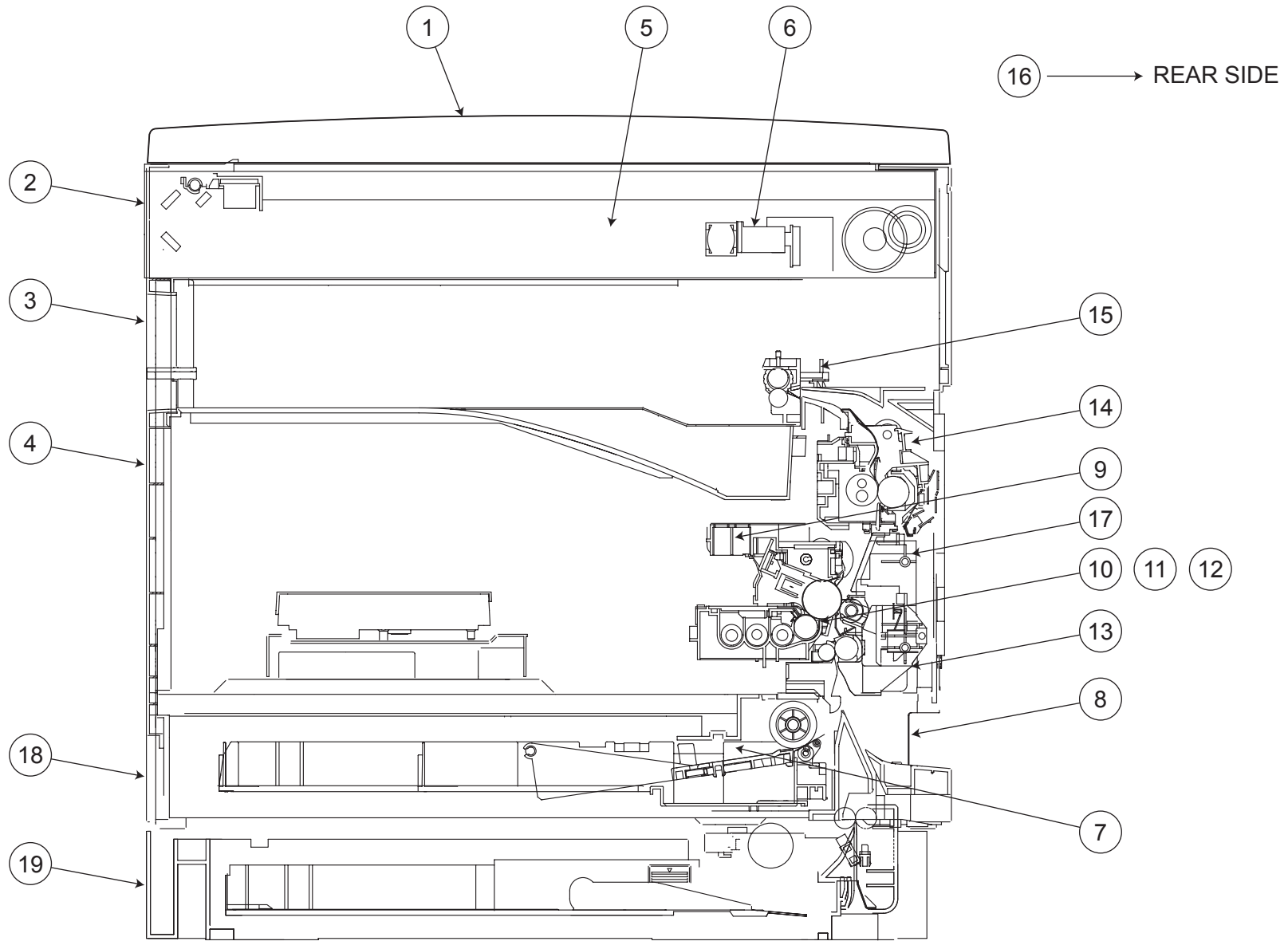

CONTENTS

No.	DESCRIPTION	PAGE No.
1	ORIGINAL COVER	P1
2	CONTROL PANEL	P2
3	HOUSING	P3
4	FRAMES	P4 P5
5	IR FRAME	P6
6	SLIDER SECTION	P7
7	PAPER TAKE-UP SECTION	P8 P9
8	MANUAL FEED SECTION	P10
9	HOPPER SECTION	P11
10	CHARGE SECTION	P12
11	DEVELOPING SECTION	P13
12	CLEANER SECTION	P14
13	TRANSPORT SECTION	P15
14	FUSING SECTION	P16
15	PAPER EXIT SECTION	P17
16	DRIVE SECTION	P18
17	ELECTRICAL COMPONENTS	P19
18	CASSETTE SECTION	P20 P21
19	PAPER FEEDER UNIT	P22 P23 P24
20	WIRING	P25 P26 P27 P28 P29
21	WIRING ACCESSORIES AND JIGS	P30
22	ACCESSORY PARTS	P31

INDEX

Parts No.	Page No.
0910 5507 12	14-17
0996 3022 01	24-29
0996 3023 01	24-31
1033 4402 01	3-24
1038 4006 01	30-8
1053 4812 01	30-7
1100 3130 08	8-9
1100 3130 08	13-38
1129 7303 01	5-10
1129 7303 01	8-3
1139 1703 02	1-6
1139 1704 14	1-5
1139 1705 01	1-3
1139 1706 01	1-7
1139 5015 01	11-4
1139 5018 04	11-18
1139 5022 01	11-10
1139 5026 01	11-12
1139 5249 01	13-41
1139 5250 01	13-40
1139 5730 01	11-31
1144 3097 03	21-4
1144 7910 01	30-16
1151 5023 01	11-13
1151 5032 01	11-20
1151 5033 02	11-19
1151 7383 01	20-12
1156 4118 02	14-20
1159 1938 01	17-5
1164 1031 01	3-2
1164 3003 01	21-17
1164 3004 03	21-19
1164 3005 02	21-18
1164 3020 03	10-20
1164 3020 03	22-12
1164 3027 01	9-11
1164 3045 01	21-24
1164 3047 02	21-11
1164 3049 02	21-23
1164 3054 01	10-16

Parts No.	Page No.
1164 3061 01	21-12
1164 3062 01	21-13
1164 3064 01	21-20
1164 3508 01	8-32
1164 3509 01	8-16
1164 3515 01	8-31
1164 4202 04	15-27
1164 4206 02	15-21
1164 4207 01	15-22
1164 4222 01	15-20
1164 5765 01	16-16
1165 4307 01	12-3
1165 4310 01	12-6
1165 5326 02	11-14
1171 1126 01	1-1
1174 5010 01	11-17
1200 1346 12	11-7
1200 3121 07	23-6
1274 2611 01	10-13
4002 0902 01	11-8
4002 7306 01	24-13
4004 3005 01	21-27
4004 3006 03	21-5
4011 0112 01	15-25
4011 2504 01	23-17
4011 3002 01	20-9
4011 3005 01	20-11
4011 3007 03	21-22
4011 3008 01	21-16
4011 3009 01	21-21
4011 3011 01	21-15
4011 3012 01	10-21
4011 3205 01	10-27
4011 3515 01	15-10
4011 5858 01	15-32
4011 5858 01	16-4
4011 7313 01	31-4
4011 7314 01	31-5
4021 0162 01	11-25
4021 0163 03	13-5

Parts No.	Page No.
4021 0165 01	13-7
4021 0166 01	14-28
4021 0202 03	13-21
4021 0204 01	18-33
4021 0306 02	12-27
4021 0752 01	13-6
4021 1009 01	3-27
4021 2014 12	5-3
4021 2018 01	8-17
4021 2019 02	15-12
4021 2020 01	19-5
4021 2025 01	10-32
4021 2031 01	8-19
4021 2101 01	8-10
4021 2103 02	8-6
4021 2106 01	8-5
4021 2110 01	5-11
4021 2307 01	15-33
4021 2316 01	8-26
4021 2501 01	18-20
4021 2502 01	18-5
4021 2503 01	18-21
4021 2504 01	18-25
4021 2505 01	18-6
4021 2509 01	18-24
4021 2510 01	18-4
4021 2511 01	18-3
4021 2512 01	18-2
4021 2517 01	18-23
4021 2519 01	18-8
4021 2533 03	18-27
4021 2538 01	18-7
4021 2540 01	18-18
4021 2541 01	18-22
4021 2542 01	18-19
4021 2547 02	18-17
4021 3001 26	20-1
4021 3004 01	22-10
4021 3013 02	21-3
4021 3014 02	21-8

Parts No.	Page No.
4021 3019 01	20-3
4021 3020 01	20-2
4021 3031 13	20-4
4021 3032 12	20-5
4021 3035 02	20-6
4021 3036 01	20-7
4021 3037 02	21-1
4021 3040 01	21-25
4021 3103 01	10-12
4021 3104 01	10-8
4021 3105 01	10-9
4021 3106 01	10-10
4021 3107 01	10-26
4021 3108 01	10-11
4021 3504 01	9-3
4021 3505 01	8-18
4021 3512 12	8-30
4021 3513 12	8-15
4021 4101 02	12-19
4021 4102 02	12-13
4021 4103 02	12-10
4021 4104 02	12-17
4021 4105 01	12-11
4021 4106 01	12-12
4021 4107 01	12-20
4021 4108 01	12-16
4021 4109 01	12-9
4021 4209 02	15-29
4021 4219 01	15-19
4021 4302 02	12-5
4021 4351 06	12-25
4021 4352 06	12-14
4021 4362 01	12-24
4021 4367 01	12-22
4021 4368 02	14-16
4021 5203 03	13-35
4021 5205 01	14-29
4021 5206 01	14-30
4021 5207 01	12-18
4021 5211 01	13-20

Parts No.	Page No.
4021 5212 02	13-19
4021 5213 01	13-18
4021 5214 01	13-23
4021 5219 01	13-25
4021 5220 01	14-31
4021 5221 01	13-29
4021 5224 02	13-44
4021 5225 01	13-9
4021 5226 01	13-15
4021 5227 01	13-22
4021 5231 01	13-12
4021 5232 01	13-13
4021 5235 03	13-32
4021 5301 02	11-11
4021 5302 01	11-22
4021 5303 01	11-15
4021 5304 01	11-2
4021 5305 02	11-26
4021 5306 02	11-30
4021 5307 02	11-29
4021 5309 01	11-21
4021 5310 01	11-16
4021 5311 01	11-28
4021 5312 01	11-27
4021 5313 04	11-1
4021 5314 01	11-9
4021 5315 01	11-6
4021 5316 02	11-23
4021 5601 06	12-26
4021 5604 02	12-1
4021 5606 01	14-21
4021 5607 02	14-34
4021 5608 01	14-35
4021 5609 01	14-33
4021 5611 01	14-32
4021 5614 02	14-24
4021 5615 01	14-25
4021 5616 01	14-27
4021 5617 01	14-23
4021 5618 01	14-11

Parts No.	Page No.	Parts No.	Page No.	Parts No.	Page No.	Parts No.	Page No.	Parts No.	Page No.
4021 5619 01	14-15	4034 1001 01	3-23	4034 2023 01	9-8	4034 3006 01	9-10	4034 5241 01	13-3
4021 5623 01	14-2	4034 1006 01	3-8	4034 2024 02	4-10	4034 3012 01	21-28	4034 5242 01	13-2
4021 5720 02	16-20	4034 1007 01	3-17	4034 2028 01	8-7	4034 3014 01	20-8	4034 5243 01	13-1
4021 5724 01	16-31	4034 1014 01	3-18	4034 2029 01	8-4	4034 3014 01	24-5	4034 5301 01	11-32
4021 5725 03	16-32	4034 1052 01	3-20	4034 2030 02	4-11	4034 3016 01	20-13	4034 5622 01	14-22
4021 5726 03	16-23	4034 1053 01	3-1	4034 2031 02	5-1	4034 3102 01	10-14	4034 5702 01	16-12
4021 5727 01	16-25	4034 1054 01	3-12	4034 2032 01	19-4	4034 3104 01	10-7	4034 5708 03	16-17
4021 5733 01	16-24	4034 1055 01	3-6	4034 2033 01	19-6	4034 3105 01	10-5	4034 5711 01	16-18
4021 5742 01	16-15	4034 1056 01	3-3	4034 2038 01	10-34	4034 3106 01	10-1	4034 5714 02	16-10
4021 5802 01	17-10	4034 1057 01	3-4	4034 2101 01	5-9	4034 3107 01	10-3	4034 5715 01	16-11
4021 5814 01	17-13	4034 1058 01	3-22	4034 2107 01	8-11	4034 3501 01	15-16	4034 5716 01	16-19
4021 5815 01	17-4	4034 1059 01	3-5	4034 2108 01	8-12	4034 3503 02	15-23	4034 5722 01	16-29
4021 5819 01	17-12	4034 1101 01	1-4	4034 2111 01	8-13	4034 3504 01	9-5	4034 5723 01	16-28
4021 5824 01	17-1	4034 1201 01	2-1	4034 2112 01	8-33	4034 3508 01	15-11	4034 5741 01	16-34
4021 6505 01	12-4	4034 1202 01	2-2	4034 2201 01	19-15	4034 3509 02	8-29	4034 5751 01	16-3
4021 6818 01	25-1	4034 1205 01	2-1	4034 2202 01	19-1	4034 3510 01	15-1	4034 5752 01	16-14
4021 6820 01	25-2	4034 1206 01	2-2	4034 2203 01	19-13	4034 3511 02	15-14	4034 5753 01	16-8
4021 6831 01	25-3	4034 1207 01	2-1	4034 2204 03	4-5	4034 3512 02	15-30	4034 5755 01	16-13
4021 6844 01	25-4	4034 1208 01	2-2	4034 2205 01	4-4	4034 3513 02	15-31	4034 5756 01	16-7
4021 7301 03	3-21	4034 1343 01	3-11	4034 2206 02	9-9	4034 3514 02	15-15	4034 5761 01	16-30
4021 7319 01	31-4	4034 1348 01	3-10	4034 2301 01	15-34	4034 3515 01	15-17	4034 5763 01	16-2
4021 7322 01	3-13	4034 1349 01	3-7	4034 2302 01	8-28	4034 3517 01	15-24	4034 5782 01	16-1
4021 7903 01	30-12	4034 1381 01	2-6	4034 2303 01	8-23	4034 3518 01	15-26	4034 5784 01	16-6
4021 7904 01	30-13	4034 1382 01	2-8	4034 2304 01	8-25	4034 3519 02	15-8	4034 5785 01	16-5
4028 0105 02	19-9	4034 1383 01	2-7	4034 2305 01	8-27	4034 3521 01	9-16	4034 5786 01	16-33
4030 2080 01	4-3	4034 1571 01	1-2	4034 2506 01	18-30	4034 3522 01	9-6	4034 5787 01	16-21
4030 5204 01	13-26	4034 2007 01	4-1	4034 2507 01	18-29	4034 3523 01	9-15	4034 5801 01	17-14
4030 7500 01	3-25	4034 2008 01	4-8	4034 2508 01	18-28	4034 3524 01	9-14	4034 5802 01	17-7
4034 0101 06	19-16	4034 2010 03	8-34	4034 2515 03	18-31	4034 3525 01	9-13	4034 5803 01	17-8
4034 0151 01	21-9	4034 2011 01	5-4	4034 2517 01	18-26	4034 3527 01	9-4	4034 5804 01	17-16
4034 0201 02	18-10	4034 2012 01	17-2	4034 2535 02	8-8	4034 3528 01	9-1	4034 5805 02	17-11
4034 0751 00	16-35	4034 2013 01	5-5	4034 2536 01	18-11	4034 3530 02	15-7	4034 5806 02	17-6
4034 0752 00	16-35	4034 2014 01	8-22	4034 2537 01	18-32	4034 3531 02	8-1	4034 5807 02	17-3
4034 0754 00	16-35	4034 2015 01	4-2	4034 2538 01	18-9	4034 3532 02	8-2	4034 5808 01	17-9
4034 0755 00	15-18	4034 2016 02	19-7	4034 2540 01	18-15	4034 3534 01	9-2	4034 5809 01	17-17
4034 0756 00	8-21	4034 2017 01	10-25	4034 2550 01	18-13	4034 3535 01	15-13	4034 6071 01	2-10
4034 0757 00	21-10	4034 2018 01	10-15	4034 3001 01	10-19	4034 3538 01	15-6	4034 6072 01	2-10
4034 0758 00	5-8	4034 2019 01	10-6	4034 3004 01	10-22	4034 3539 01	15-4	4034 6073 01	2-10
4034 0759 00	12-15	4034 2021 01	8-35	4034 3005 01	20-16	4034 3550 01	15-5	4034 6074 01	2-10
4034 0760 01	30-15	4034 2022 01	5-2	4034 3005 01	24-20	4034 5202 01	13-27	4034 6201 02	19-11

Parts No.	Page No.	Parts No.	Page No.	Parts No.	Page No.	Parts No.	Page No.	Parts No.	Page No.
4034 6202 02	19-11	4034 7402 01	16-9	4163 5293 01	13-17	4508 1003 01	2-20	4508 1048 01	7-3
4034 6205 03	19-2	4034 7403 01	16-9	4163 5293 01	15-28	4508 1004 01	2-19	4508 1049 01	7-1
4034 6801 01	4-6	4034 7404 01	16-9	4163 5293 01	17-15	4508 1005 01	2-15	4508 1050 01	7-2
4034 6805 01	25-5	4034 7507 01	31-1	4163 5293 01	20-10	4508 1006 01	2-3	4508 1051 01	7-15
4034 6806 01	25-6	4034 7603 01	31-2	4163 5293 01	24-33	4508 1008 01	7-42	4508 1052 01	7-14
4034 6810 02	25-7	4034 7901 01	30-14	4163 5296 02	13-4	4508 1009 01	6-1	4508 1053 01	7-12
4034 6811 01	25-8	4037 0104 01	10-23	4163 5298 01	13-11	4508 1010 01	7-34	4508 1054 01	7-16
4034 6812 01	25-9	4037 0104 01	22-11	4163 5603 02	14-19	4508 1011 01	7-38	4508 1055 01	7-17
4034 6813 01	25-10	4037 3210 01	21-14	4163 5604 03	14-6	4508 1012 01	7-39	4508 1056 01	7-18
4034 6815 01	27-1	4037 7406 01	3-16	4163 5605 03	14-36	4508 1013 01	7-20	4508 1057 01	7-36
4034 6816 01	26-1	4109 2003 01	24-18	4163 5606 04	14-4	4508 1014 01	6-2	4508 1058 01	7-19
4034 6817 01	26-2	4128 1978 01	5-7	4163 5607 02	14-3	4508 1015 01	7-35	4508 1059 01	7-31
4034 6819 01	26-3	4128 1979 01	5-6	4163 5609 01	14-13	4508 1016 01	7-26	4508 1060 01	7-30
4034 6821 01	26-4	4152 5620 02	4-12	4163 5611 01	14-12	4508 1017 01	6-9	4508 1061 01	7-23
4034 6822 01	26-5	4156 3826 01	22-13	4163 5612 02	12-2	4508 1018 01	6-8	4508 1062 01	7-28
4034 6825 02	28-5	4162 4074 01	14-7	4163 5614 01	14-18	4508 1019 01	6-5	4508 1063 01	7-27
4034 6827 01	16-26	4163 4072 01	14-9	4163 5617 01	14-5	4508 1019 01	6-17	4508 1064 01	7-24
4034 6830 01	26-6	4163 4103 01	12-8	4163 5620 01	14-1	4508 1020 01	6-7	4508 1065 01	7-25
4034 6834 01	26-7	4163 4104 02	12-7	4163 5625 01	14-14	4508 1021 01	6-6	4508 1066 01	7-32
4034 6835 01	26-8	4163 4116 01	12-21	4163 5639 01	14-26	4508 1023 01	6-4	4508 1067 01	7-33
4034 6836 01	26-9	4163 4361 04	14-8	4163 6051 01	13-42	4508 1024 01	2-13	4508 1068 01	7-13
4034 6837 01	28-1	4163 4370 01	14-10	4192 1464 01	15-9	4508 1025 01	2-12	4508 1069 01	2-14
4034 6840 01	28-2	4163 5101 01	13-24	4498 3328 01	23-31	4508 1026 01	6-14	4537 0901 01	9-17
4034 6847 01	29-1	4163 5102 01	11-24	4498 3333 02	23-32	4508 1027 01	6-12	4537 0901 01	10-18
4034 6860 01	28-3	4163 5102 01	13-16	4498 3345 04	24-11	4508 1028 01	6-11	4537 0901 01	10-24
4034 6880 01	27-2	4163 5217 01	13-33	4498 3388 01	9-7	4508 1029 01	6-10	4537 0901 01	16-27
4034 6881 02	28-4	4163 5221 01	13-43	4498 3404 01	24-3	4508 1030 01	7-41	4603 3205 01	10-4
4034 7306 01	15-2	4163 5226 01	13-10	4498 3826 01	24-10	4508 1031 01	7-40	4603 3218 01	10-29
4034 7309 01	3-19	4163 5229 02	13-30	4498 3833 01	24-6	4508 1032 01	2-4	4647 1039 01	2-17
4034 7310 01	15-35	4163 5230 03	13-8	4506 1002 01	2-18	4508 1033 01	2-11	4658 3035 02	21-2
4034 7330 01	20-15	4163 5231 02	13-14	4506 1004 01	2-22	4508 1035 01	6-15	4658 3040 01	21-7
4034 7331 01	10-2	4163 5237 01	13-36	4506 1005 01	2-16	4508 1037 01	2-21	4658 3046 01	21-26
4034 7332 01	10-2	4163 5244 01	13-39	4506 1021 01	7-7	4508 1038 01	6-16	4658 3047 01	21-6
4034 7333 01	15-3	4163 5245 01	13-31	4506 1029 01	7-29	4508 1041 01	6-3	4658 3144 02	23-29
4034 7334 01	3-26	4163 5260 01	13-28	4506 1034 01	7-11	4508 1042 01	7-9	4658 3516 01	18-14
4034 7335 01	3-26	4163 5271 01	13-34	4506 1035 01	7-22	4508 1043 01	7-8	4658 7305 01	31-6
4034 7338 01	3-15	4163 5272 01	13-37	4506 1036 01	7-21	4508 1044 01	7-37	4686 0101 01	22-9
4034 7339 01	3-14	4163 5293 01	8-24	4506 4008 01	7-10	4508 1045 01	7-4	4686 0210 01	23-27
4034 7340 01	3-13	4163 5293 01	11-3	4508 1001 01	6-13	4508 1046 01	7-6	4686 0211 01	24-23
4034 7341 01	3-13	4163 5293 01	12-23	4508 1002 01	2-5	4508 1047 01	7-5	4686 0902 01	10-17

Parts No.	Page No.
4686 0902 01	23-16
4686 0903 01	22-6
4686 0903 01	23-1
4686 3304 01	4-9
4686 3304 01	10-33
4686 3304 01	22-14
4686 3306 03	22-21
4686 3307 01	23-10
4686 3308 01	23-13
4686 3310 01	23-2
4686 3312 01	23-20
4686 3313 01	23-30
4686 3314 01	23-33
4686 3316 01	23-28
4686 3317 02	22-16
4686 3318 01	22-5
4686 3319 01	22-17
4686 3320 14	24-24
4686 3321 01	24-14
4686 3322 01	24-12
4686 3323 02	24-32
4686 3324 02	24-30
4686 3325 02	24-16
4686 3326 03	24-15
4686 3327 01	24-25
4686 3328 01	24-2
4686 3329 01	24-19
4686 3330 01	24-27
4686 3333 01	23-25
4686 3334 01	23-3
4686 3335 01	22-2
4686 3336 01	23-18
4686 3337 01	23-4
4686 3341 01	23-14
4686 3343 01	23-9
4686 3346 01	24-8
4686 3347 01	24-9
4686 3348 02	24-21
4686 3349 01	24-22
4686 3350 01	20-14

Parts No.	Page No.
4686 3350 01	24-17
4686 3351 01	23-7
4686 3353 01	23-19
4686 3354 01	23-24
4686 3355 01	23-26
4686 3356 01	23-22
4686 3357 01	23-21
4686 3358 01	23-11
4686 3359 01	23-12
4686 3360 01	23-5
4686 3361 01	23-8
4686 3362 01	22-3
4686 3364 01	22-4
4686 3365 01	24-1
4686 3366 01	24-26
4686 3367 01	24-28
4686 3369 01	22-7
4686 3371 01	23-23
4686 3372 01	22-1
4686 3373 01	22-15
4686 3374 01	22-18
4686 3375 01	24-7
4686 6801 02	29-2
4686 6802 04	29-3
4686 7315 01	24-4
4687 3262 01	10-30
4687 7304 01	10-31
9312 1100 11	11-5
9313 1300 12	19-12
9313 1300 31	15-36
9314 1300 11	18-1
9314 2300 12	18-12
9321 2100 22	23-15
9321 2300 21	10-28
9321 2300 21	18-16
9322 1300 11	8-14
9326 1000 51	19-14
9326 1100 11	2-23
9326 2820 11	1-8
9331 1810 11	19-3

Parts No.	Page No.
9331 2300 11	8-20
9332 5810 11	4-7
9335 1300 61	2-9
9335 1300 61	9-12
9372 2300 41	16-22
9381 4101 31	31-3
9381 4300 31	31-3
9381 4300 41	31-3
9381 4300 91	31-3
9384 1000 51	30-1
9384 1100 91	30-4
9384 1100 91	30-4
9384 1310 11	30-18
9384 1310 81	30-17
9384 1310 91	30-2
9384 1311 11	30-11
9384 1621 21	3-9
9384 1621 21	19-10
9384 1900 54	30-5
9384 1900 56	19-8
9384 1900 56	22-8
9384 1911 11	30-6
9384 1921 11	30-3
9384 2010 21	30-9
9384 2010 21	30-19
9384 2910 31	30-10

ORIGINAL COVER

CHINA ONLY

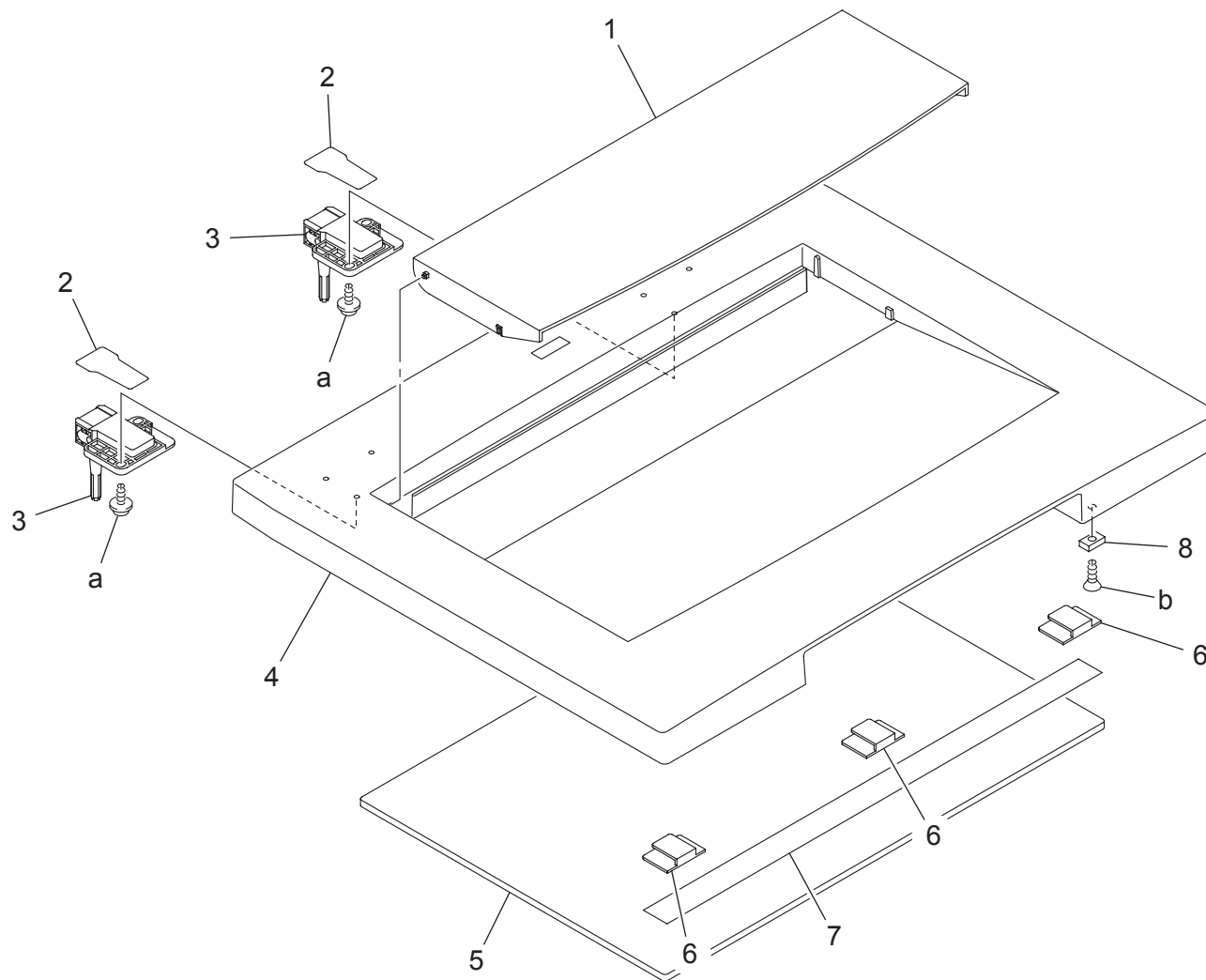

ORIGINAL COVER

Key	Part No.	Description	Destinations	Class	QTY	Standard parts
1	1171 1126 01	ORIGINAL HOLDER	J	C	1	a-9739 0412 14 b-9657 0314 07
2	4034 1571 01	COVER	J	C	2	
3	1139 1705 01	HINGE	J	C	2	
4	4034 1101 01	ORIGINAL COVER	J	C	1	
5	1139 1704 14	PAD	J	C	1	
6	1139 1703 02	SLIDER	J	D	3	
7	1139 1706 01	SEAL	J	C	1	
8	9326 2820 11	MAGNET	J	D	1	

CONTROL PANEL

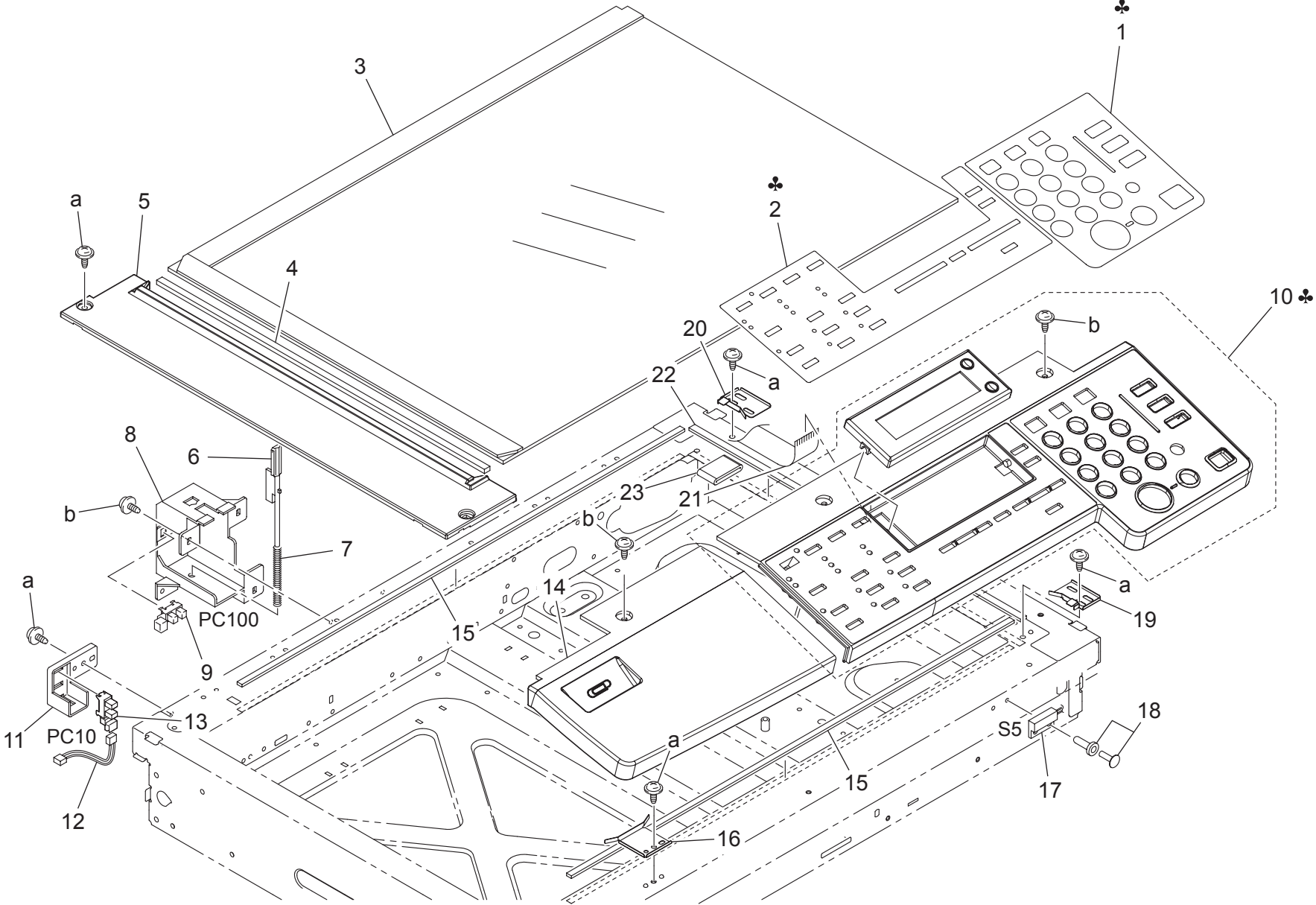

CONTROL PANEL

Key	Part No.	Description	Destinations	Class	QTY	Standard parts
1	4034 1201 01	FACE SHEET	B,D,E,F1,F2,G1,G2,I,K	S	1	a-9735 0306 14 b-9735 0308 14
1	4034 1205 01	FACE SHEET	H	S	1	
1	4034 1207 01	FACE SHEET	J	S	1	
2	4034 1202 01	FACE SHEET	B,D,E,F1,F2,G1,G2,I,K	S	1	
2	4034 1206 01	FACE SHEET	H	S	1	
2	4034 1208 01	FACE SHEET	J	S	1	
3	4508 1006 01	ORIGINAL GLASS		C	1	
4	4508 1032 01	SEAL		C	1	
5	4508 1002 01	COVER		C	1	
6	4034 1381 01	LEVER		C	1	
7	4034 1383 01	PRESSURE SPRING		C	1	
8	4034 1382 01	HOLDER		D	1	
9	9335 1300 61	PHOTO INTERRUPTER		B	1	
10	4034 6071 01	CONTROL PANEL ASSY	B,C,D,E,F1,F2,G1,G2,I,K	C	1	
10	4034 6072 01	CONTROL PANEL ASSY	C	C	1	
10	4034 6073 01	CONTROL PANEL ASSY	J	C	1	
10	4034 6074 01	CONTROL PANEL ASSY	H	C	1	
11	4508 1033 01	COVER		C	1	
12	4508 1025 01	WIRE HARNESS ASSY		D	1	
13	4508 1024 01	PHOTOINTTRUPTTER		B	1	
14	4508 1069 01	COVER		C	1	
15	4508 1005 01	SEAL		C	2	
16	4506 1005 01	SET PLATE		C	1	
17	4647 1039 01	MAGNETIC SW		C	1	
18	4506 1002 01	PIN		D	1	
19	4508 1004 01	PLATE SPRING		D	1	
20	4508 1003 01	PLATE SPRING		C	1	
21	4508 1037 01	WIRE HARNESS ASSY		D	1	
22	4506 1004 01	CUSHION		C	1	
23	9326 1100 11	FERRITE CORE		D	1	

HOUSING

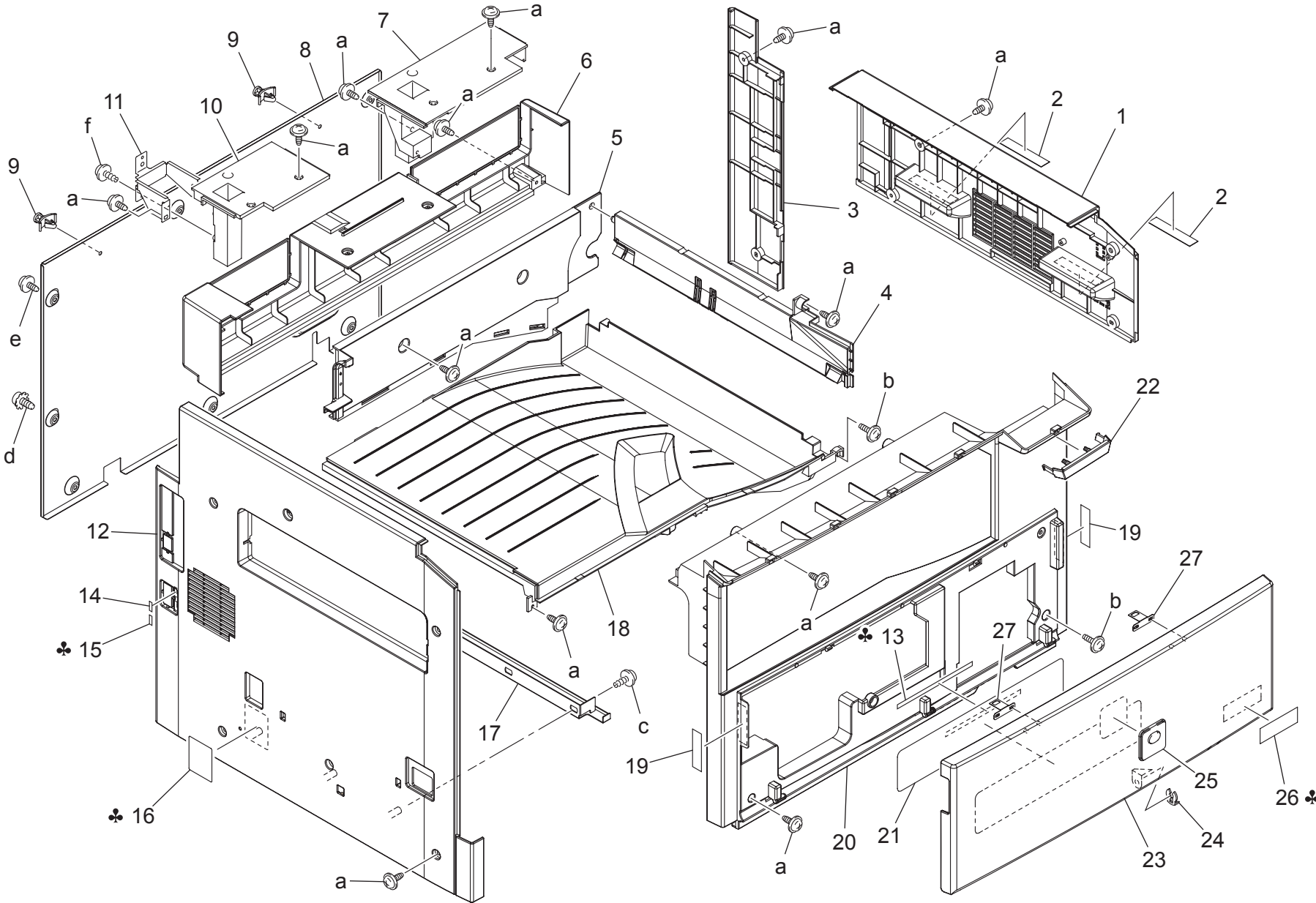

Key	Part No.	Description	Destinations	Class	QTY	Standard parts
1	4034 1053 01	RIGHT UPPER COVER		C	1	a-9735 0308 14 b-9739 0408 14 c-9739 0410 14 d-9770 0308 14 e-9735 0306 14 f-9739 0308 14
2	1164 1031 01	SEAL		C	2	
3	4034 1056 01	RIGHT REAR COVER		C	1	
4	4034 1057 01	INSIDE RIGHT COVER		C	1	
5	4034 1059 01	INSIDE REAR COVER		C	1	
6	4034 1055 01	REAR COVER		C	1	
7	4034 1349 01	HOLDER		C	1	
8	4034 1006 01	REAR COVER		D	1	
9	9384 1621 21	PWB SUPPORT 6.4H		D	2	
10	4034 1348 01	HOLDER		C	1	
11	4034 1343 01	REINFORCE PLATE		D	1	
12	4034 1054 01	LEFT COVER		C	1	
13	4021 7322 01	LABEL TONER INSTUCTION	J	C	1	
13	4034 7340 01	LABEL TONER INSTUCTION	B,D,E,F1,F2,G1,G2,H,I,K	C	1	
13	4034 7341 01	LABEL TONER INSTUCTION	C	C	1	
14	4034 7339 01	LABEL LINE		C	1	
15	4034 7338 01	LABEL TEL	B,D,E,F1,F2,G1,G2,H,I,J,K	C	1	
16	4037 7406 01	LABEL EARTH CAUTION	C,D,E,F2,G1,I,K	C	1	
17	4034 1007 01	GUIDE		D	1	
18	4034 1014 01	TRAY		C	1	
19	4034 7309 01	LABEL		C	2	
20	4034 1052 01	FRONT COVER		C	1	
21	4021 7301 03	LABEL TONER REPLENISHMENT		C	1	
22	4034 1058 01	COVER		C	1	
23	4034 1001 01	FRONT DOOR		C	1	
24	1033 4402 01	STOPPER RING		D	1	
25	4030 7500 01	LABEL LOGO MARK		C	1	
26	4034 7334 01	LABEL bizhub 210	C,D,E,F1,F2,G1,G2,H,I,J,K	C	1	
26	4034 7335 01	LABEL bizhub 180	B	C	1	
27	4021 1009 01	REINFORCE PLATE		C	2	

FRAMES

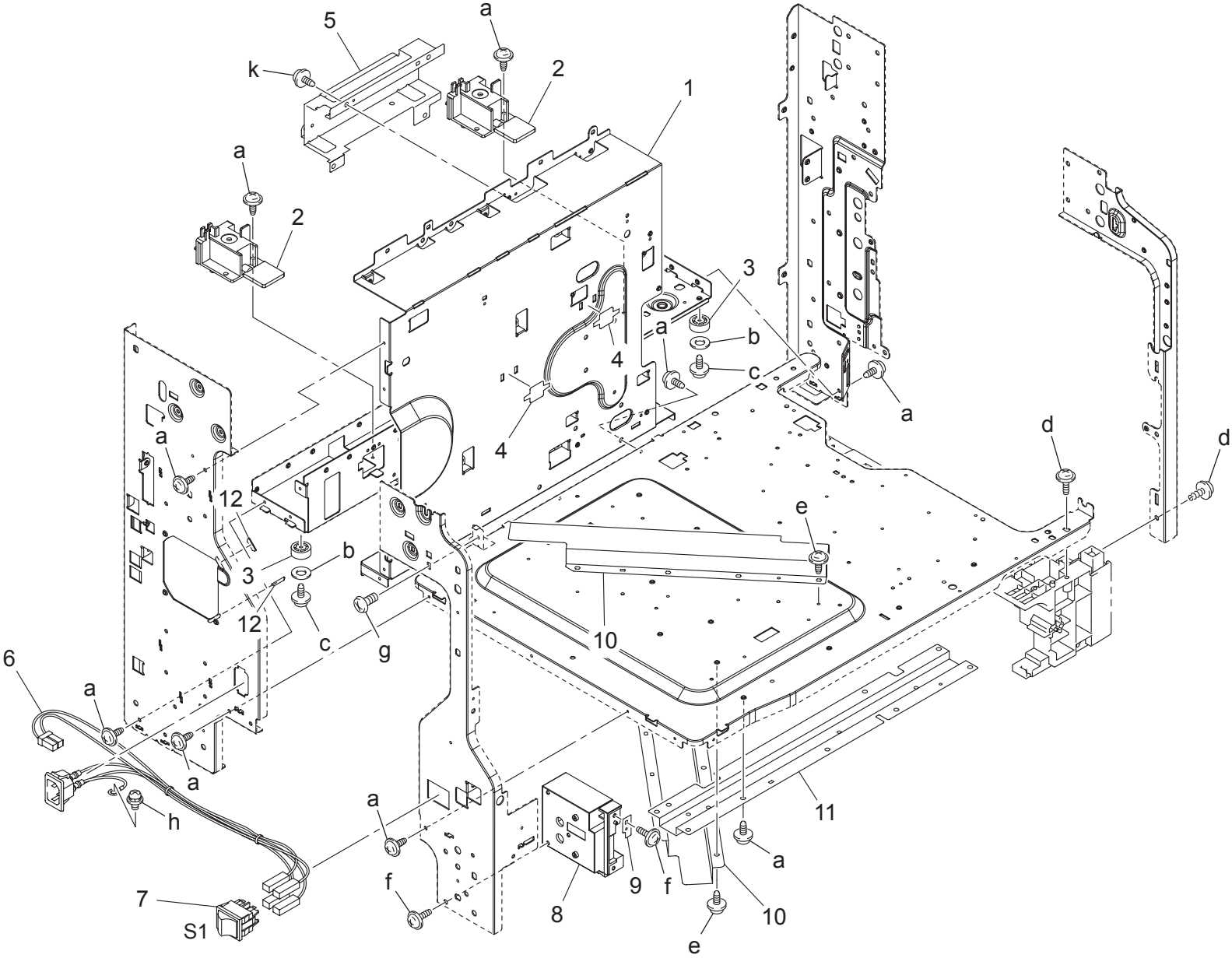

FRAMES

Key	Part No.	Description	Destinations	Class	QTY	Standard parts
1	4034 2007 01	BRACKET		D	1	a-9735 0306 14 b-9716 0300 01 c-9735 0310 14 d-9739 0408 14 e-4154 3804 01 f-9739 0410 14 g-9654 0408 14 h-9646 0408 14 k-9735 0308 14
2	4034 2015 01	STOP PLATE		D	2	
3	4030 2080 01	RUBBER FOOT		D	2	
4	4034 2205 01	SUPPORTER		D	2	
5	4034 2204 03	BRACKET		D	1	
6	4034 6801 01	WIRE HARNESS ASSY		D	1	
7	9332 5810 11	SWITCH		C	1	
8	4034 2008 01	FRAME		D	1	
9	4686 3304 01	STOPPER		D	1	
10	4034 2024 02	REINFORCE PLATE		D	2	
11	4034 2030 02	REINFORCE PLATE		D	1	
12	4152 5620 02	SEAL		C	2	

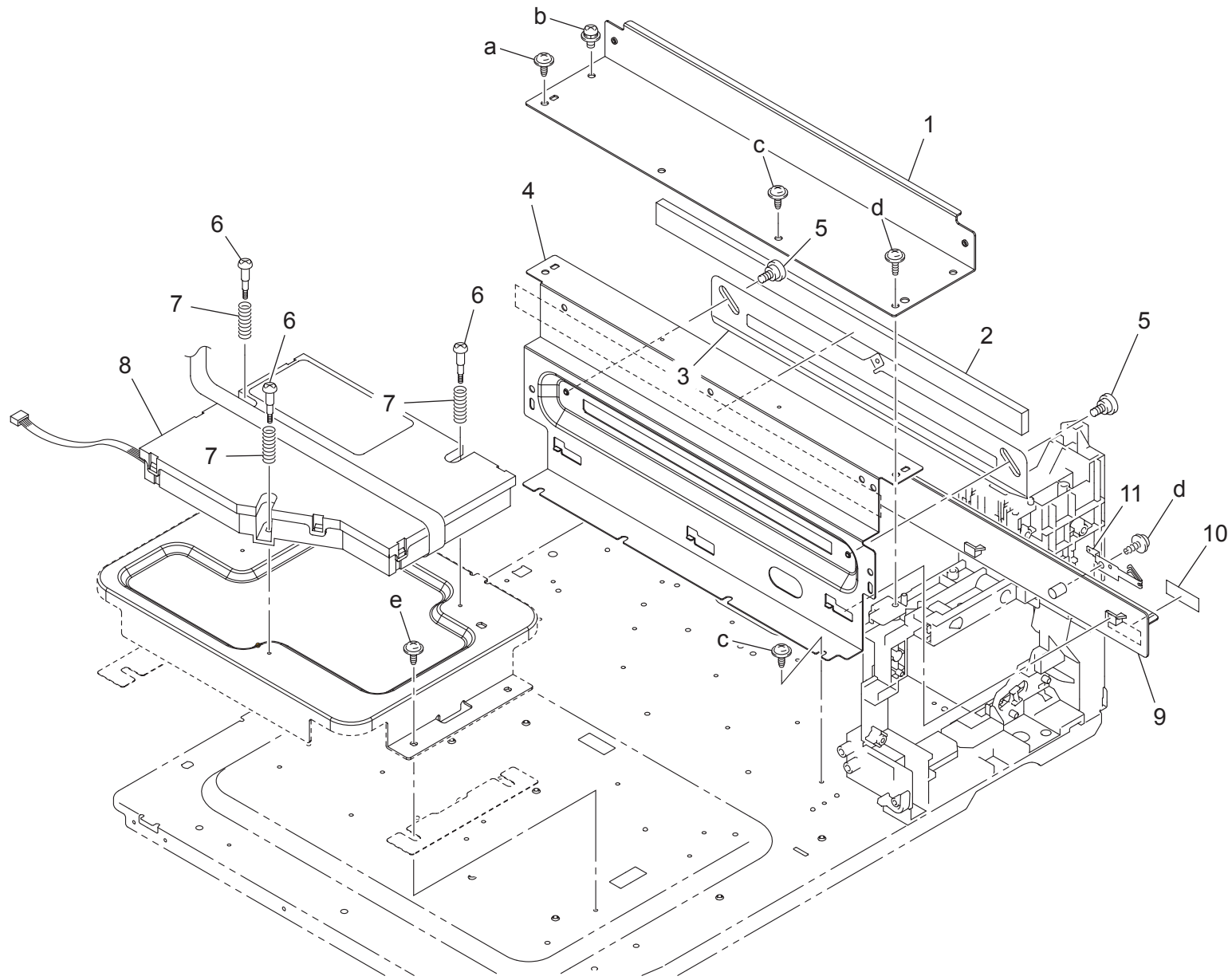

FRAMES

Key	Part No.	Description	Destinations	Class	QTY	Standard parts
1	4034 2031 02	BRACKET		D	1	a-9735 0308 14 b-9646 0310 14 c-9735 0306 14 d-9739 0408 14 e-4106 2063 01
2	4034 2022 01	SEAL		C	1	
3	4021 2014 12	SHUTTER		D	1	
4	4034 2011 01	BRACKET		D	1	
5	4034 2013 01	SHOULDER SCREW		C	2	
6	4128 1979 01	SHOULDER SCREW		C	3	
7	4128 1978 01	PRESSURE SPRING		C	3	
8	4034 0758 00	P/H ASSY		I	1	
9	4034 2101 01	HOLDER		D	1	
10	1129 7303 01	LABEL HI-VOL CAUTION		D	1	
11	4021 2110 01	CONTACT		C	1	

IR FRAME

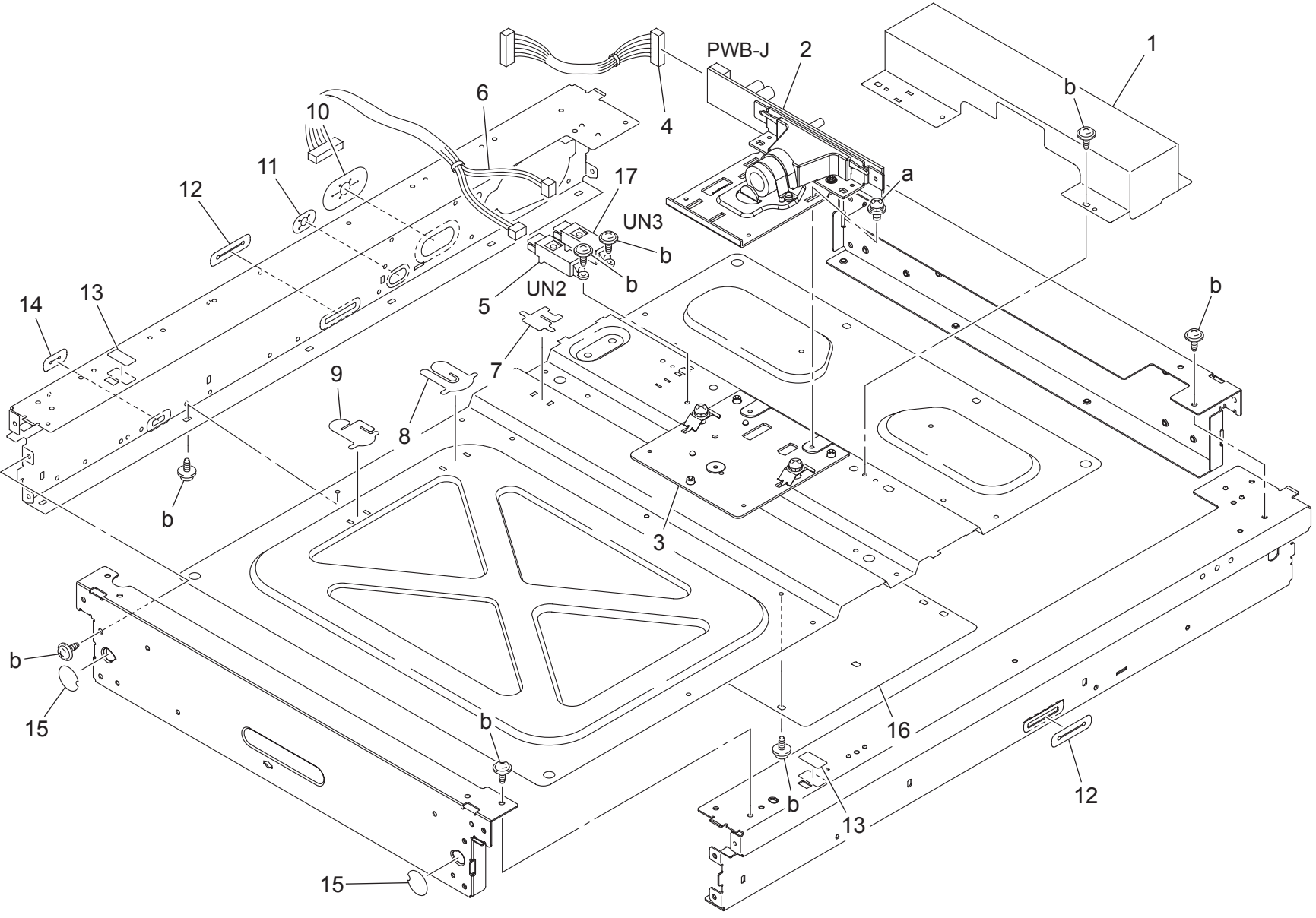

IR FRAME

Key	Part No.	Description	Destinations	Class	QTY	Standard parts
1	4508 1009 01	COVER		D	1	a-9646 0306 14 b-9735 0306 14
2	4508 1014 01	LENS ASSY		I	1	
3	4508 1041 01	PLATE		I	1	
4	4508 1023 01	WIRE HARNESS ASSY		D	1	
5	4508 1019 01	PHOTOINTRUPTTER		B	1	
6	4508 1021 01	WIRE HARNESS ASSY		D	1	
7	4508 1020 01	SEAL		C	1	
8	4508 1018 01	SEAL		C	1	
9	4508 1017 01	SEAL		C	1	
10	4508 1029 01	SEAL		C	1	
11	4508 1028 01	SEAL		C	1	
12	4508 1027 01	SEAL		C	2	
13	4508 1001 01	SEAL		C	2	
14	4508 1026 01	SEAL		C	1	
15	4508 1035 01	SEAL		C	2	
16	4508 1038 01	SET PLATE		D	1	
17	4508 1019 01	PHOTOINTRUPTTER	(OPTION)	B	1	

SLIDER SECTION

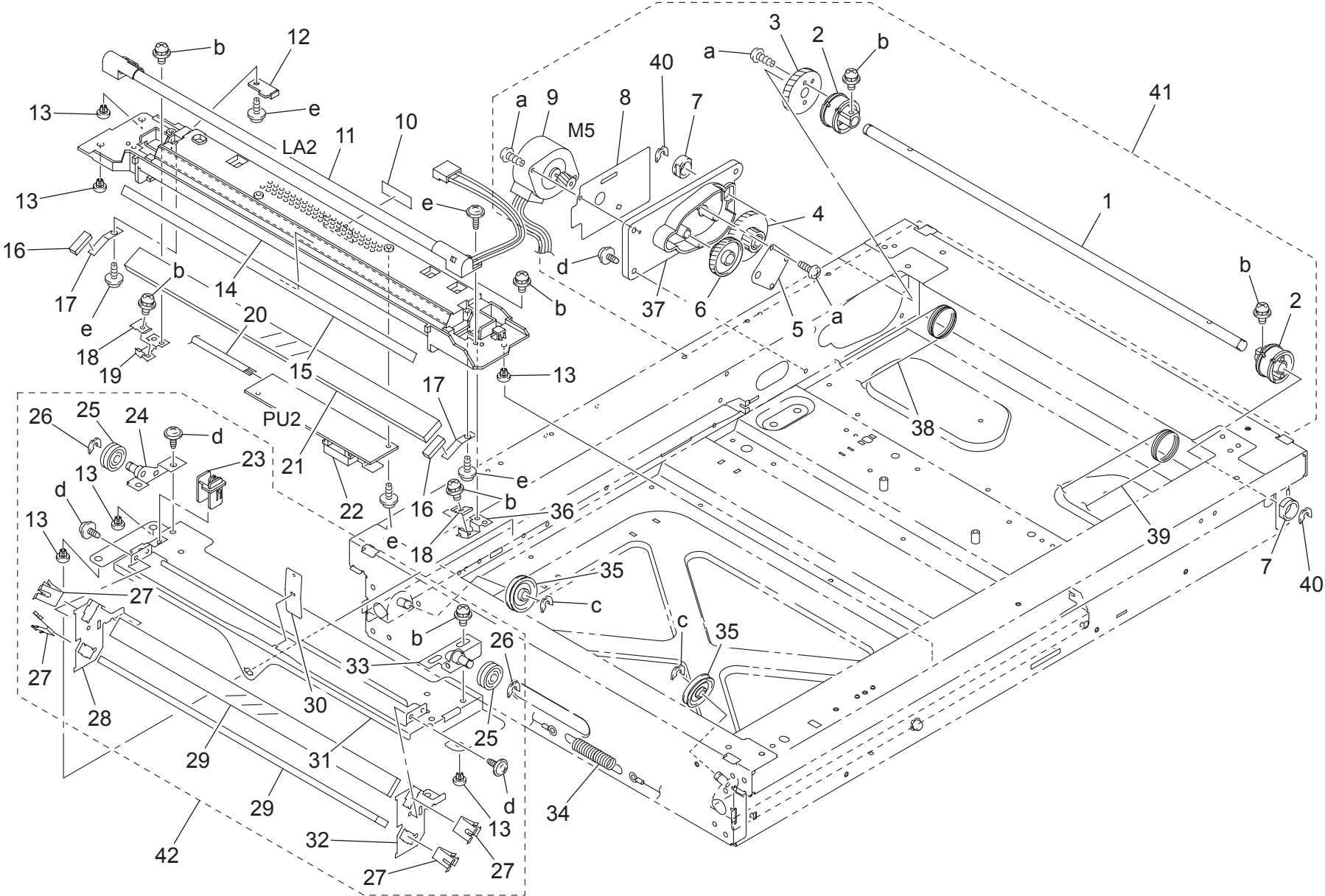

SLIDER SECTION

Key	Part No.	Description	Destinations	Class	QTY	Standard parts
1	4508 1049 01	SHAFT		D	1	a-9732 0308 14 b-9646 0308 14 c-4425 3001 01 d-9735 0306 14 e-9739 0308 14
2	4508 1050 01	PULLEY		C	2	
3	4508 1048 01	GEAR		C	1	
4	4508 1045 01	GEAR		C	1	
5	4508 1047 01	WASHER		D	1	
6	4508 1046 01	GEAR		C	1	
7	4506 1021 01	BUSHING		C	2	
8	4508 1043 01	BRACKET		D	1	
9	4508 1042 01	MOTOR		B	1	
10	4506 4008 01	LABEL		D	1	
11	4506 1034 01	LAMP		B	1	
12	4508 1053 01	STOPPER		D	1	
13	4508 1068 01	SLIDER		D	6	
14	4508 1052 01	FRAME		D	1	
15	4508 1051 01	REFLECTOR		C	1	
16	4508 1054 01	SEAL		C	2	
17	4508 1055 01	HOLDER		D	2	
18	4508 1056 01	SET PLATE		D	2	
19	4508 1058 01	BRACKET		D	1	
20	4508 1013 01	WIRE HARNESS ASSY		D	1	
21	4506 1036 01	MIRROR		C	1	
22	4506 1035 01	INVERTER		I	1	
23	4508 1061 01	GUIDE		D	1	
24	4508 1064 01	BRACKET		D	1	
25	4508 1065 01	PULLEY		C	2	
26	4508 1016 01	WASHER		D	2	
27	4508 1063 01	PLATE SPRING		D	4	
28	4508 1062 01	BRACKET		D	1	
29	4506 1029 01	MIRROR		C	2	
30	4508 1060 01	PLATE SPRING		D	1	
31	4508 1059 01	FRAME		D	1	
32	4508 1066 01	BRACKET		D	1	
33	4508 1067 01	BRACKET		D	1	
34	4508 1010 01	TENSION SPRING		C	1	
35	4508 1015 01	PULLEY		C	2	
36	4508 1057 01	BRACKET		D	1	
37	4508 1044 01	HOLDER		D	1	
38	4508 1011 01	WIRE		C	1	
39	4508 1012 01	WIRE		C	1	
40	4508 1031 01	WASHER		D	2	
41	4508 1030 01	DRIVING ASSY		C	1	
42	4508 1008 01	2ND SLIDE ASSY		S	1	

PAPER TAKE-UP SECTION

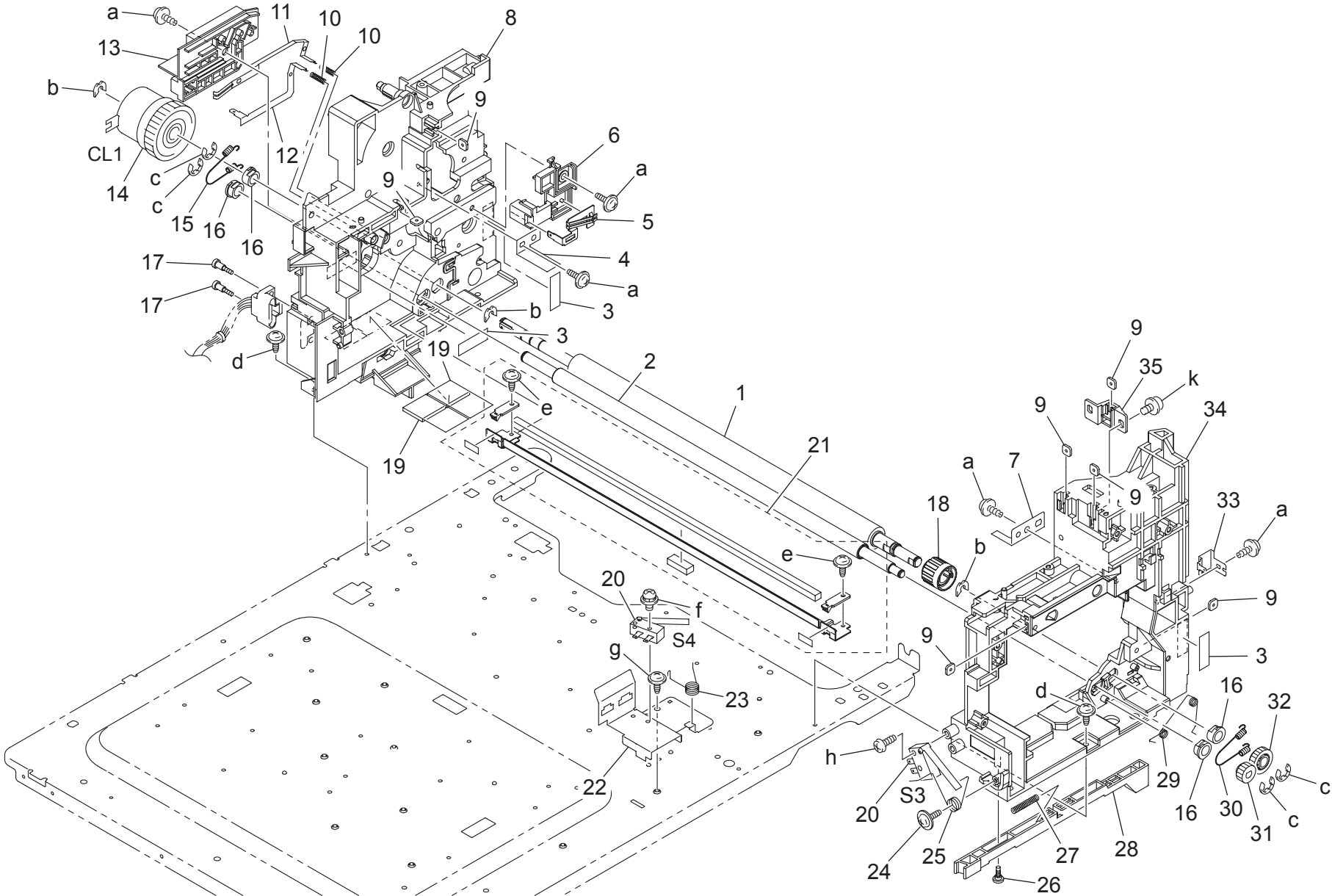

PAPER TAKE-UP SECTION

Key	Part No.	Description	Destinations	Class	QTY	Standard parts
1	4034 3531 02	ROLLER		C	1	a-9739 0408 14 b-1066 1151 01 c-9721 0500 01 d-4154 3804 01 e-9735 0306 14 f-9646 0316 14 g-4106 2063 01 h-9742 0318 14 k-9646 0308 14
2	4034 3532 02	ROLLER		C	1	
3	1129 7303 01	LABEL HI-VOL CAUTION		D	3	
4	4034 2029 01	POSITIONING PLATE		D	1	
5	4021 2106 01	CONTACT		C	1	
6	4021 2103 02	HOLDER		D	1	
7	4034 2028 01	BRACKET		D	1	
8	4034 2535 02	FRAME		D	1	
9	1100 3130 08	PLATE NUT		D	7	
10	4021 2101 01	PRESSURE SPRING		C	2	
11	4034 2107 01	CONTACT		C	1	
12	4034 2108 01	CONTACT		C	1	
13	4034 2111 01	COVER		C	1	
14	9322 1300 11	CLUTCH		C	1	
15	4021 3513 12	TENSION SPRING		C	1	
16	1164 3509 01	BUSHING		C	4	
17	4021 2018 01	SHOULDER SCREW		C	2	
18	4021 3505 01	KNOB		C	1	
19	4021 2031 01	CUSHION		C	2	
20	9331 2300 11	MICRO-SWITCH		C	2	
21	4034 0756 00	CLEANING PAD		A	1	
22	4034 2014 01	BRACKET		D	1	
23	4034 2303 01	TORSION SPRING		C	1	
24	4163 5293 01	SCREW		C	1	
25	4034 2304 01	TORSION SPRING		C	1	
26	4021 2316 01	SHOULDER SCREW		C	1	
27	4034 2305 01	PRESSURE SPRING		C	1	
28	4034 2302 01	ARM		D	1	
29	4034 3509 02	CONTACT		C	1	
30	4021 3512 12	TENSION SPRING		C	1	
31	1164 3515 01	GEAR 13T		A	1	
32	1164 3508 01	GEAR 18T		C	1	
33	4034 2112 01	CONTACT		C	1	
34	4034 2010 03	RAIL		D	1	
35	4034 2021 01	BRACKET		D	1	

PAPER TAKE-UP SECTION

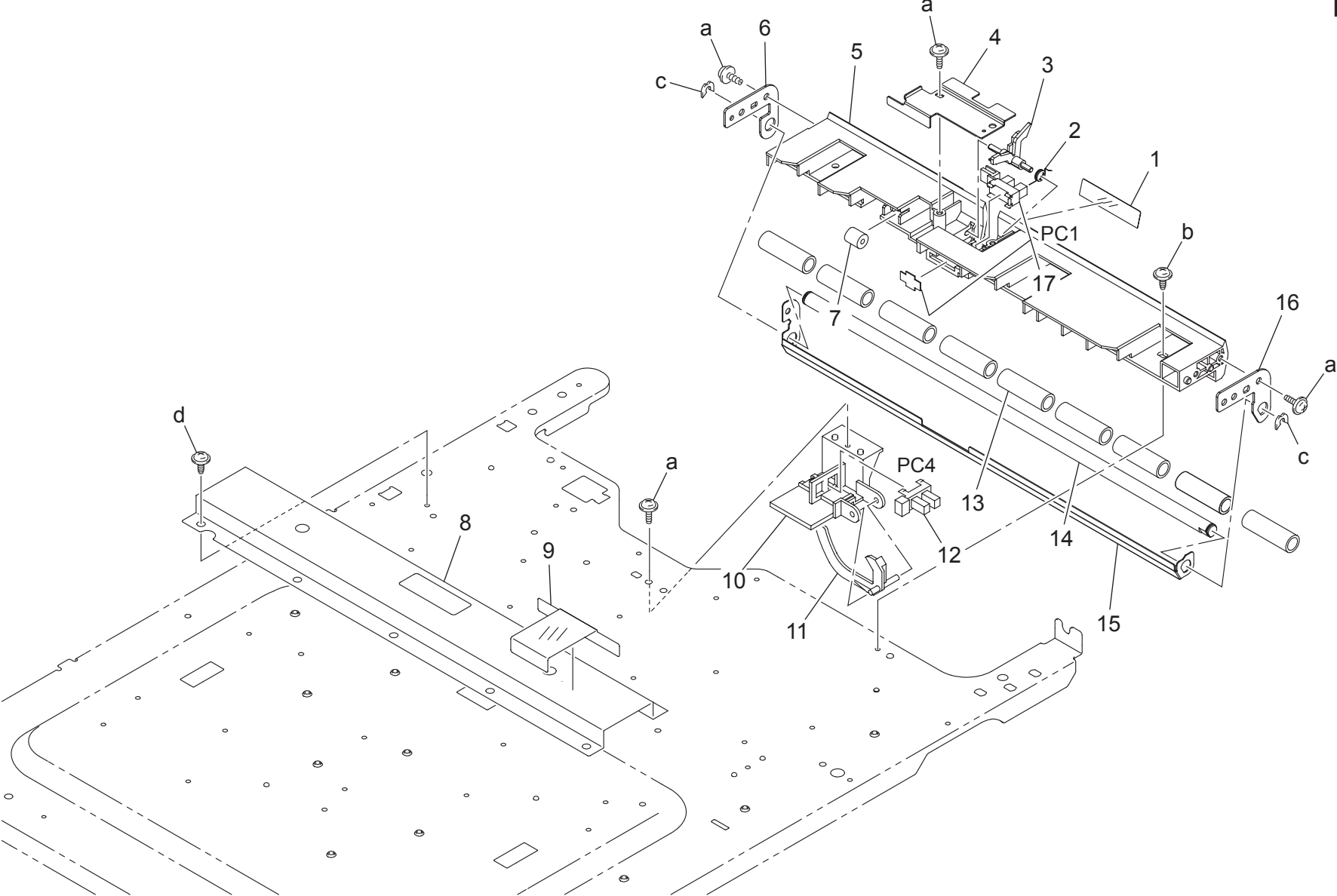

PAPER TAKE-UP SECTION

Key	Part No.	Description	Destinations	Class	QTY	Standard parts
1	4034 3528 01	GUIDE		D	1	a-9739 0308 14 b-9735 0306 14 c-1066 1151 01 d-4106 2063 01
2	4034 3534 01	TORSION SPRING		C	1	
3	4021 3504 01	ACTUATOR		C	1	
4	4034 3527 01	COVER		D	1	
5	4034 3504 01	HOLDER		D	1	
6	4034 3522 01	BRACKET		D	1	
7	4498 3388 01	COLLAR		C	1	
8	4034 2023 01	REINFORCE PLATE		D	1	
9	4034 2206 02	INSULATING MEMBER		D	1	
10	4034 3006 01	HOLDER		D	1	
11	1164 3027 01	ACTUATOR		C	1	
12	9335 1300 61	PHOTO INTERRUPTER		B	1	
13	4034 3525 01	ROLLER		C	9	
14	4034 3524 01	SHAFT		D	1	
15	4034 3523 01	GUIDE PLATE		D	1	
16	4034 3521 01	BRACKET		D	1	
17	4537 0901 01	PHOTO INTERRUPTER		B	1	

MANUAL FEED SECTION

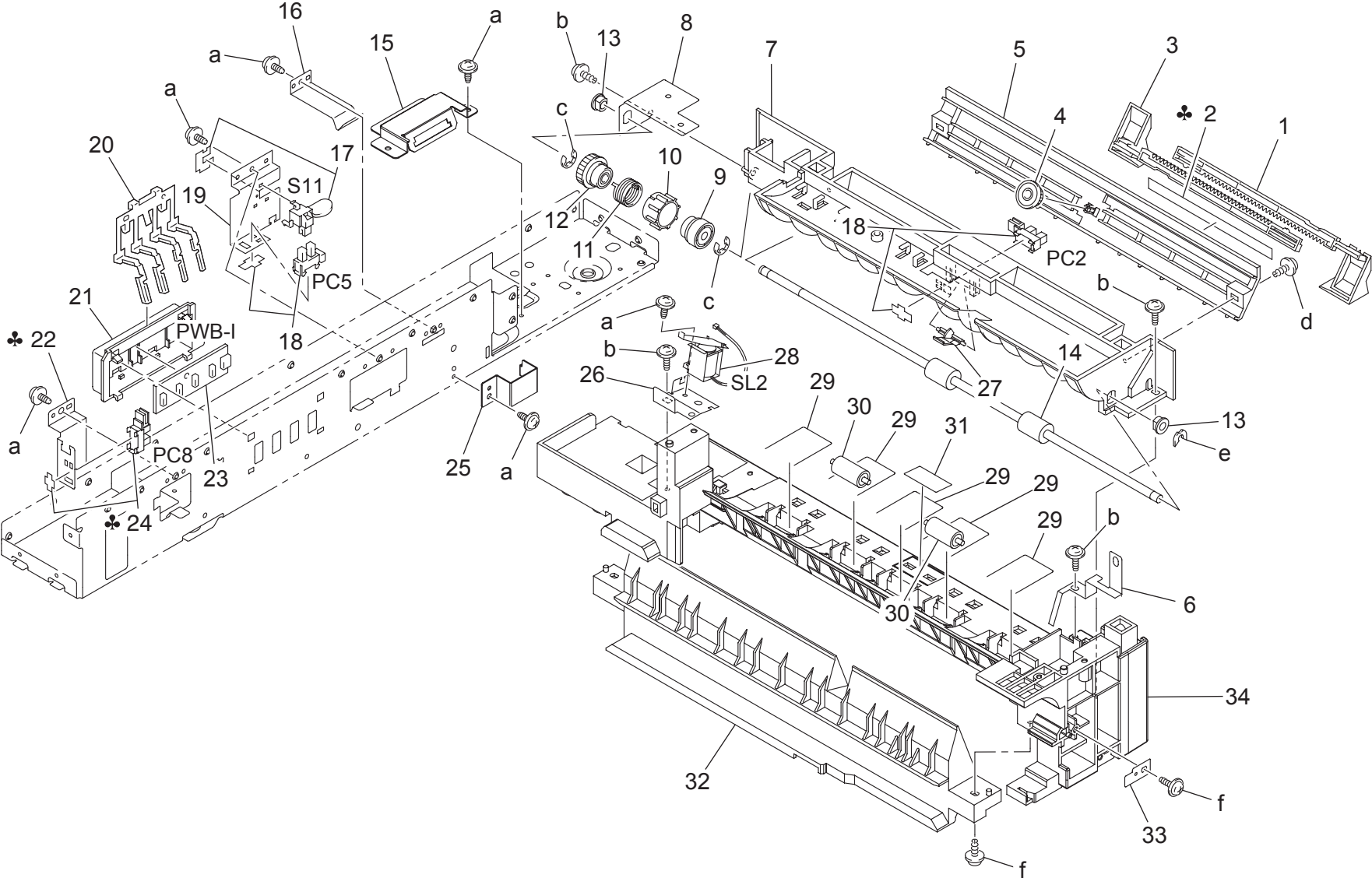

MANUAL FEED SECTION

Key	Part No.	Description	Destinations	Class	QTY	Standard parts
1	4034 3106 01	REGULATING PLATE		C	1	a-9735 0306 14 b-9739 0408 14 c-9721 0400 01 d-9739 0308 14 e-4425 3001 01 f-9739 0410 14
2	4034 7331 01	LABEL SCALE METRIC	C,D,E,F1,F2,G1,G2,H,I,J,K	C	1	
2	4034 7332 01	LABEL SCALE INCH		C	1	
3	4034 3107 01	REGULATING PLATE	B,G2	C	1	
4	4603 3205 01	GEAR 12T		C	1	
5	4034 3105 01	GUIDE		C	1	
6	4034 2019 01	PLATE SPRING		D	1	
7	4034 3104 01	RIGHT LOWER COVER		C	1	
8	4021 3104 01	BRACKET		D	1	
9	4021 3105 01	COLLAR		C	1	
10	4021 3106 01	RATCHET		C	1	
11	4021 3108 01	SPRING		C	1	
12	4021 3103 01	GEAR 29T		C	1	
13	1274 2611 01	BUSHING		C	2	
14	4034 3102 01	ROLLER		A	1	
15	4034 2018 01	BRACKET		D	1	
16	1164 3054 01	PLATE SPRING		C	1	
17	4686 0902 01	PUSHBUTTON SWITCH		C	1	
18	4537 0901 01	PHOTO INTERRUPTER		B	2	
19	4034 3001 01	BRACKET		D	1	
20	1164 3020 03	LEVER		C	1	
21	4011 3012 01	HOLDER		D	1	
22	4034 3004 01	BRACKET	D,E,F1,F2,G1,G2,I,K	D	1	
23	4037 0104 01	PWB-I		C	1	
24	4537 0901 01	PHOTO INTERRUPTER	D,E,F1,F2,G1,G2,I,K	B	1	
25	4034 2017 01	GUIDE		D	1	
26	4021 3107 01	BRACKET		D	1	
27	4011 3205 01	ACTUATOR		C	1	
28	9321 2300 21	SOLENOID		C	1	
29	4603 3218 01	SPRING		C	5	
30	4687 3262 01	ROLL		C	2	
31	4687 7304 01	LABEL PAPER		D	1	
32	4021 2025 01	RAIL		D	1	
33	4686 3304 01	STOPPER		D	1	
34	4034 2038 01	GUIDE		D	1	

HOPPER SECTION

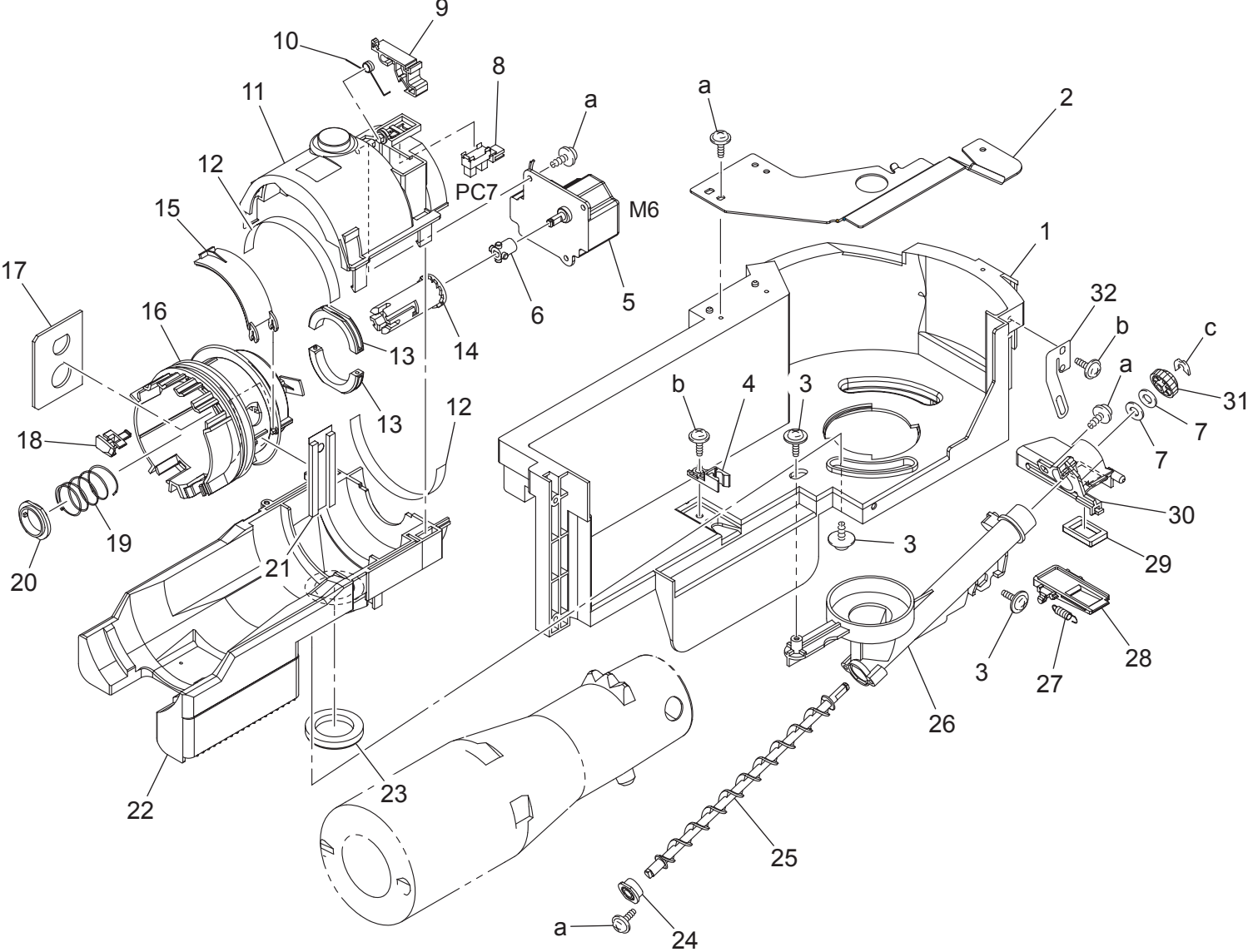

HOPPER SECTION

Key	Part No.	Description	Destinations	Class	QTY	Standard parts
1	4021 5313 04	HOLDER		D	1	a-9739 0308 14 b-9739 0410 14 c-4425 3002 01
2	4021 5304 01	BRACKET		D	1	
3	4163 5293 01	SCREW		C	3	
4	1139 5015 01	LOCK LEVER		C	1	
5	9312 1100 11	MOTOR		B	1	
6	4021 5315 01	PIN		C	1	
7	1200 1346 12	WASHER		D	2	
8	4002 0902 01	PHOTO INTERRUPTER		B	1	
9	4021 5314 01	LEVER		C	1	
10	1139 5022 01	TORSION SPRING		C	1	
11	4021 5301 02	HOLDER		D	1	
12	1139 5026 01	POLYESTER FILM		C	2	
13	1151 5023 01	SUPPORT		C	2	
14	1165 5326 02	SHAFT		D	1	
15	4021 5303 01	SHUTTER		D	1	
16	4021 5310 01	COUPLING		C	1	
17	1174 5010 01	SHEEL		C	1	
18	1139 5018 04	DETECTING PLATE		D	3	
19	1151 5033 02	PRESSURE SPRING		C	1	
20	1151 5032 01	COLLAR		C	1	
21	4021 5309 01	SEAL		C	1	
22	4021 5302 01	HOLDER		D	1	
23	4021 5316 02	SEAL		C	1	
24	4163 5102 01	BUSHING		C	1	
25	4021 0162 01	SCREW ASSY		D	1	
26	4021 5305 02	TRANSPORT PIPE		D	1	
27	4021 5312 01	SPRING		C	1	
28	4021 5311 01	SHUTTER		D	1	
29	4021 5307 02	SEAL		C	1	
30	4021 5306 02	DUCT		D	1	
31	1139 5730 01	GEAR 18T		C	1	
32	4034 5301 01	SPRING		C	1	

CHARGE SECTION

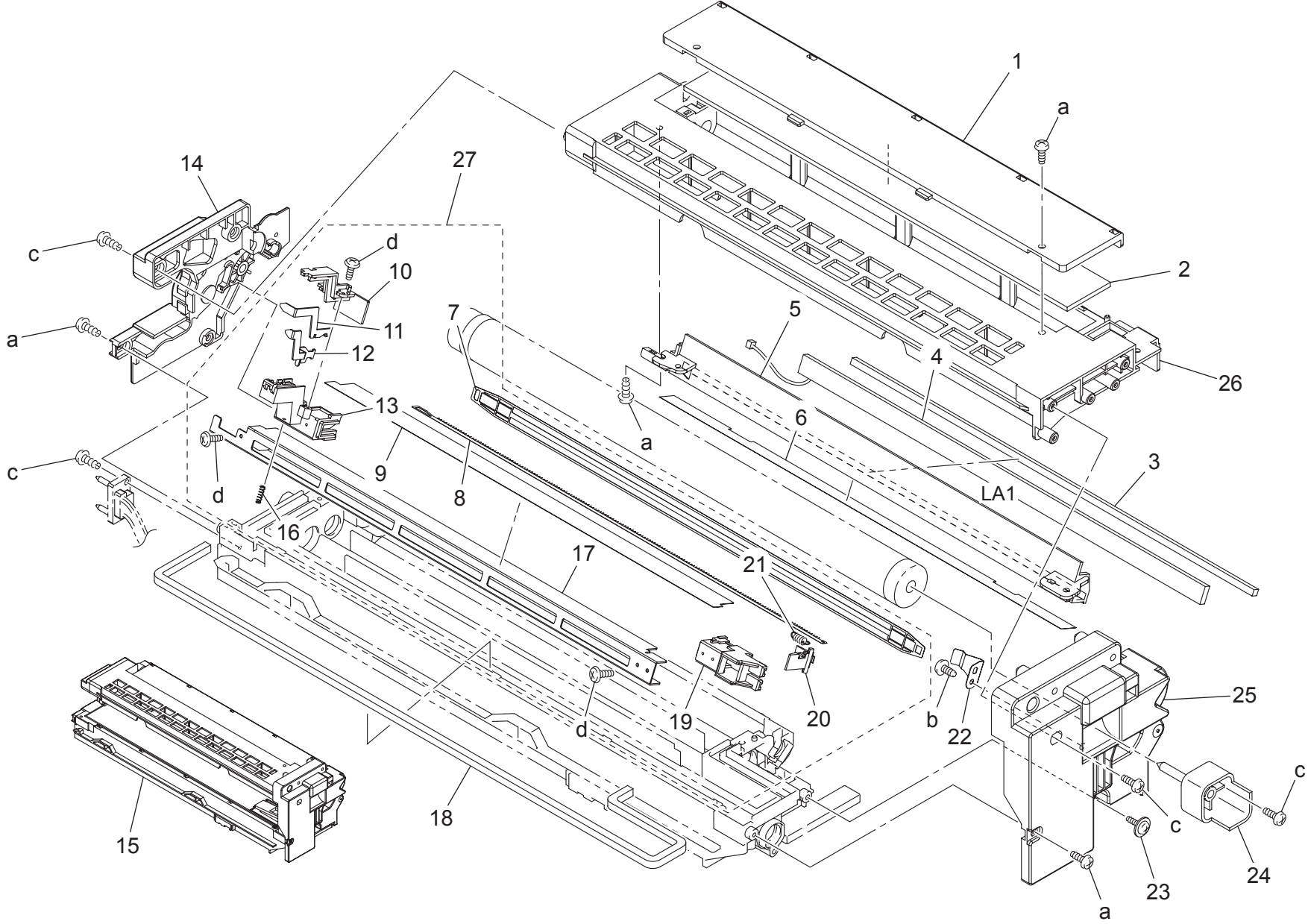

CHARGE SECTION

Key	Part No.	Description	Destinations	Class	QTY	Standard parts
1	4021 5604 02	LID		D	1	a-9742 0308 07 b-9739 0308 07 c-9742 0310 07 d-9747 1740 07
2	4163 5612 02	SEAL		C	1	
3	1165 4307 01	SEAL		C	1	
4	4021 6505 01	LED PILOT LAMP		B	1	
5	4021 4302 02	HOLDER		D	1	
6	1165 4310 01	SEAL		C	1	
7	4163 4104 02	GRID		B	1	
8	4163 4103 01	ELECTRODE NEEDLE		B	1	
9	4021 4109 01	SHIELD PLATE		C	1	
10	4021 4103 02	COVER		C	1	
11	4021 4105 01	TERMINAL		C	1	
12	4021 4106 01	TERMINAL		C	1	
13	4021 4102 02	HOLDER		D	1	
14	4021 4352 06	BRACKET		D	1	
15	4034 0759 00	IU ASSY		A	1	
16	4021 4108 01	SPRING		C	1	
17	4021 4104 02	PLATE		D	1	
18	4021 5207 01	SEAL		C	1	
19	4021 4101 02	HOLDER		D	1	
20	4021 4107 01	LEVER		C	1	
21	4163 4116 01	TENSION SPRING		C	1	
22	4021 4367 01	PLATE SPRING		D	1	
23	4163 5293 01	SCREW		C	1	
24	4021 4362 01	PIN		S	1	
25	4021 4351 06	BRACKET		D	1	
26	4021 5601 06	HOUSING		D	1	
27	4021 0306 02	DRUM CHARGE UNIT		A	1	

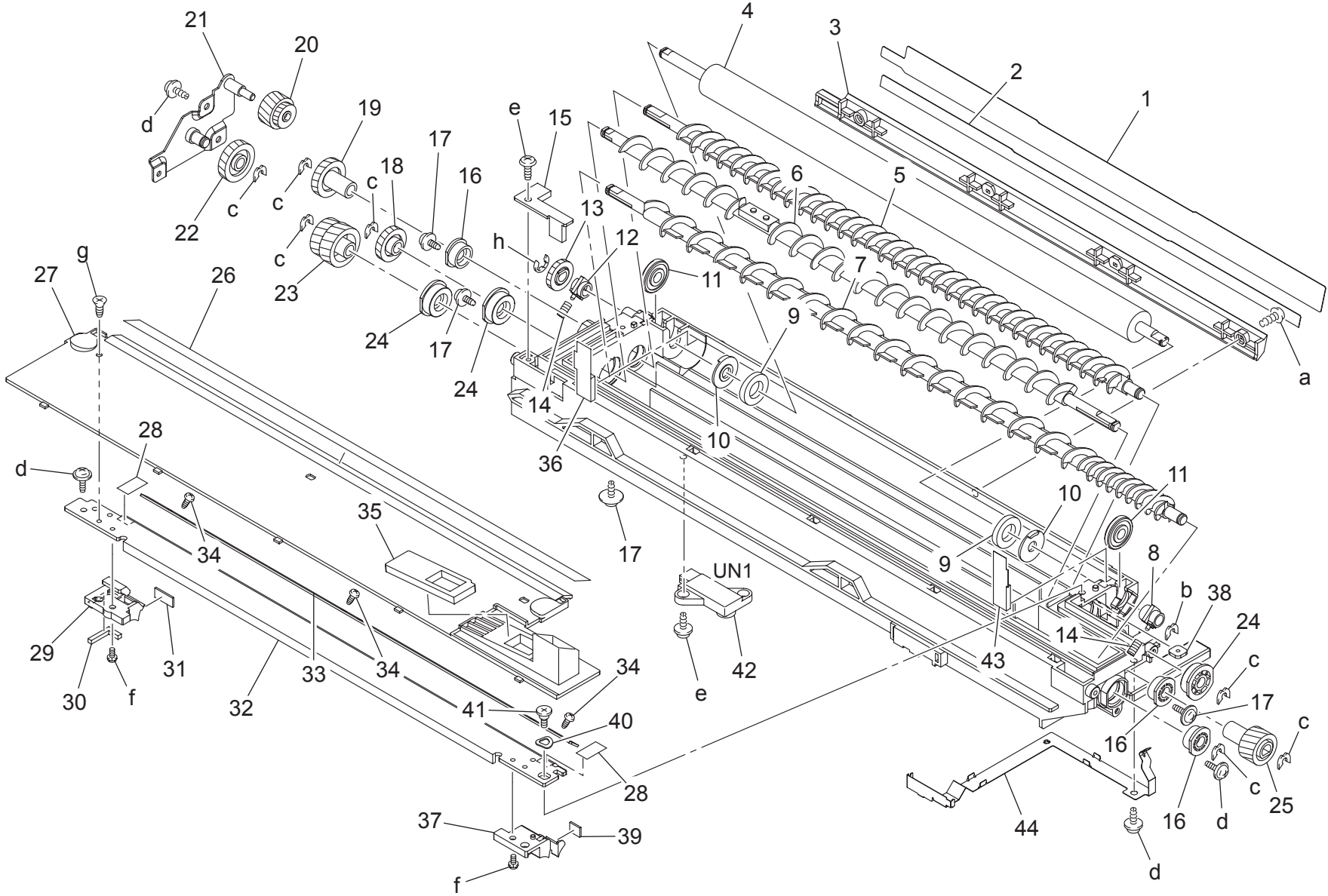

Key	Part No.	Description	Destinations	Class	QTY	Standard parts
1	4034 5243 01	GUIDE		D	1	a-9747 1750 07 b-4425 3002 01 c-4425 3001 01 d-9739 0308 07 e-9742 0308 07 f-9644 0304 21 g-9648 0306 14 h-9721 0400 01
2	4034 5242 01	GUIDE		D	1	
3	4034 5241 01	GUIDE		D	1	
4	4163 5296 02	DEVELOPING ROLLER		B	1	
5	4021 0163 03	SCREW ASSY		D	1	
6	4021 0752 01	SCREW ASSY		C	1	
7	4021 0165 01	SCREW ASSY		D	1	
8	4163 5230 03	BUSHING		C	1	
9	4021 5225 01	SEAL		C	2	
10	4163 5226 01	HOLDER		D	2	
11	4163 5298 01	ROLL		C	2	
12	4021 5231 01	BUSHING		C	1	
13	4021 5232 01	GEAR 19T		C	1	
14	4163 5231 02	PRESSURE SPRING		C	2	
15	4021 5226 01	COVER		C	1	
16	4163 5102 01	BUSHING		C	3	
17	4163 5293 01	SCREW		C	4	
18	4021 5213 01	GEAR 20T		C	1	
19	4021 5212 02	GEAR 18T		C	1	
20	4021 5211 01	GEAR 15/15T		C	1	
21	4021 0202 03	BRACKET ASSY		D	1	
22	4021 5227 01	GEAR 19T		C	1	
23	4021 5214 01	GEAR 18/24T		C	1	
24	4163 5101 01	BUSHING		C	3	
25	4021 5219 01	GEAR 15T		C	1	
26	4030 5204 01	SEAL		C	1	
27	4034 5202 01	LID		D	1	
28	4163 5260 01	SEAL		C	2	
29	4021 5221 01	GUIDE		D	1	
30	4163 5229 02	SEAL		C	1	
31	4163 5245 01	MAGNET		D	1	
32	4021 5235 03	BRACKET		D	1	
33	4163 5217 01	REGULATING PLATE		C	1	
34	4163 5271 01	SCREW		D	3	
35	4021 5203 03	SEAL		C	1	
36	4163 5237 01	SEAL		C	1	
37	4163 5272 01	GUIDE		D	1	
38	1100 3130 08	PLATE NUT		D	1	
39	4163 5244 01	MAGNET		D	1	
40	1139 5250 01	PLATE SPRING		C	1	
41	1139 5249 01	SHOULDER SCREW		C	1	
42	4163 6051 01	UN1		B	1	
43	4163 5221 01	SEAL		C	1	
44	4021 5224 02	CONTACT		C	1	

CLEANER SECTION

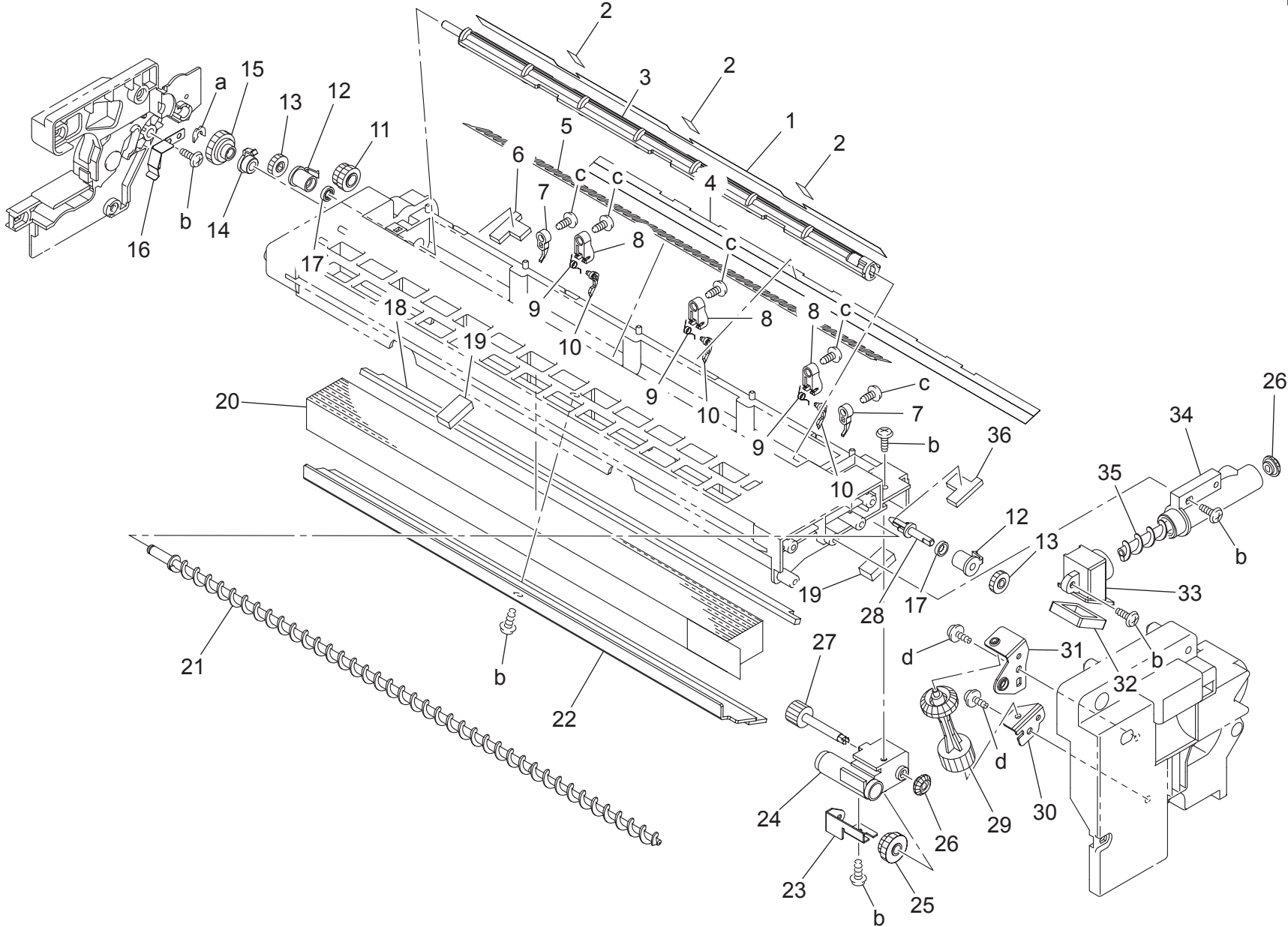

CLEANER SECTION

Key	Part No.	Description	Destinations	Class	QTY	Standard parts
1	4163 5620 01	SEAL		C	1	a-4425 3002 01 b-9742 0308 07 c-9747 1740 07 d-9739 0308 07
2	4021 5623 01	SEAL		C	3	
3	4163 5607 02	SCREW		C	1	
4	4163 5606 04	SEAL		C	1	
5	4163 5617 01	SEAL		C	1	
6	4163 5604 03	SEAL		C	1	
7	4162 4074 01	GUIDE		D	2	
8	4163 4361 04	HOLDER		D	3	
9	4163 4072 01	TORSION SPRING		C	3	
10	4163 4370 01	SEPARATOR		A	3	
11	4021 5618 01	GEAR 14/16T		C	1	
12	4163 5611 01	BUSHING		C	2	
13	4163 5609 01	GEAR 14T		C	2	
14	4163 5625 01	BUSHING		C	1	
15	4021 5619 01	GEAR 22T		C	1	
16	4021 4368 02	PLATE SPRING		D	1	
17	0910 5507 12	SEAL		C	2	
18	4163 5614 01	SEAL		C	1	
19	4163 5603 02	SEAL		C	2	
20	1156 4118 02	OZONE FILTER		A	1	
21	4021 5606 01	SCREW		D	1	
22	4034 5622 01	CLEANING BLADE		A	1	
23	4021 5617 01	BRACKET		D	1	
24	4021 5614 02	HOLDER		D	1	
25	4021 5615 01	GEAR 14/14T		C	1	
26	4163 5639 01	GEAR 14T		C	2	
27	4021 5616 01	GEAR 14T		C	1	
28	4021 0166 01	SHAFT		D	1	
29	4021 5205 01	GEAR 15/18T		C	1	
30	4021 5206 01	BRACKET		D	1	
31	4021 5220 01	BRACKET		D	1	
32	4021 5611 01	SEAL		C	1	
33	4021 5609 01	DUCT		D	1	
34	4021 5607 02	DUCT		D	1	
35	4021 5608 01	SCREW		D	1	
36	4163 5605 03	SEAL		C	1	

TRANSPORT SECTION

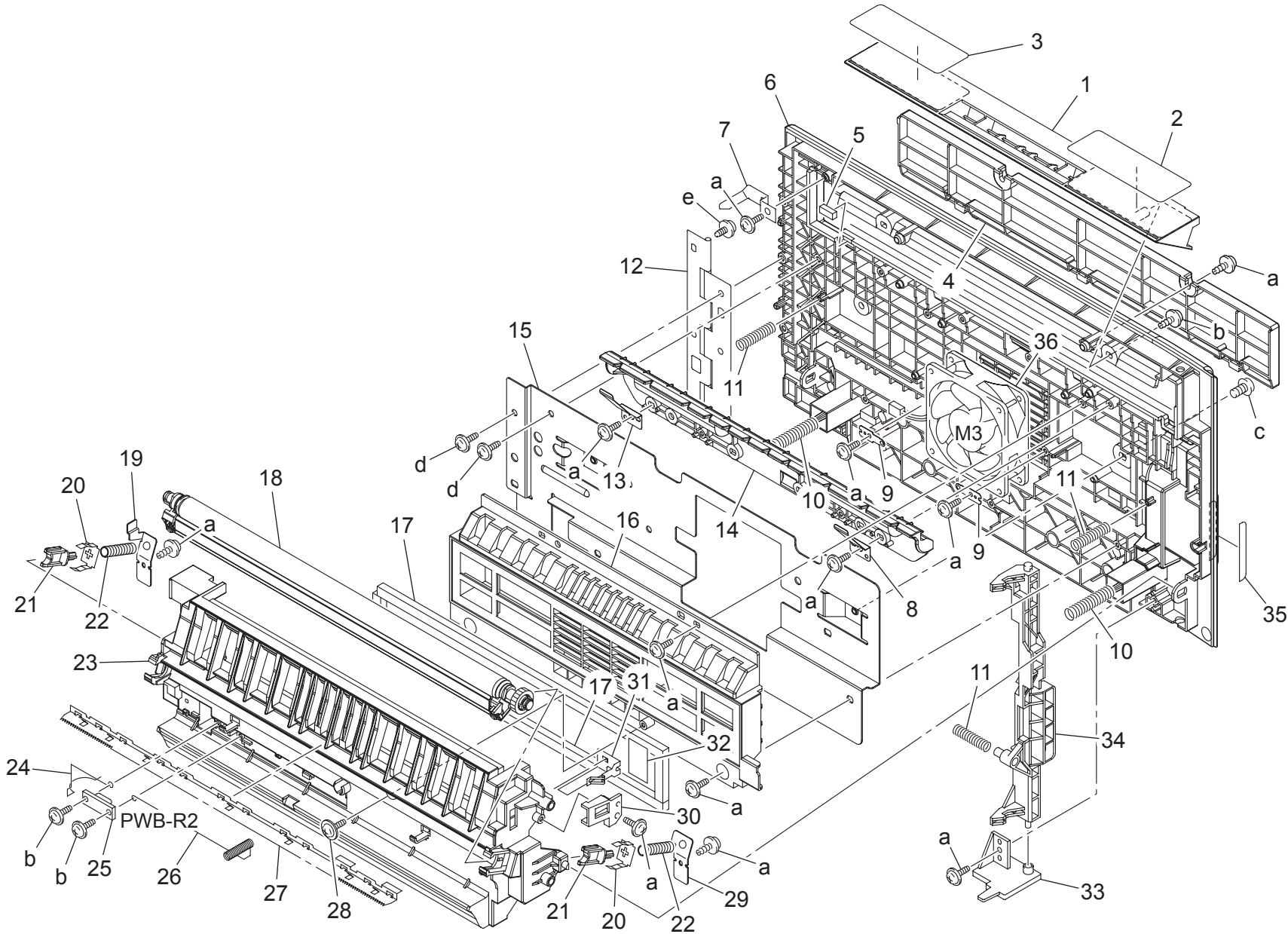

TRANSPORT SECTION

Key	Part No.	Description	Destinations	Class	QTY	Standard parts
1	4034 3510 01	GUIDE		D	1	a-9739 0308 14 b-9739 0310 14 c-9654 0408 14 d-9739 0410 14 e-9735 0408 14
2	4034 7306 01	LABEL JAM REMOVAL		D	1	
3	4034 7333 01	LABEL JAM REMOVAL		C	1	
4	4034 3539 01	COVER		C	1	
5	4034 3550 01	CUSHION		C	1	
6	4034 3538 01	RIGHT DOOR		C	1	
7	4034 3530 02	LEVER		C	1	
8	4034 3519 02	PLATE SPRING		D	1	
9	4192 1464 01	PLATE SPRING		D	2	
10	4011 3515 01	PRESSURE SPRING		C	2	
11	4034 3508 01	PRESSURE SPRING		C	3	
12	4021 2019 02	HINGE		C	1	
13	4034 3535 01	PLATE SPRING		D	1	
14	4034 3511 02	GUIDE		D	1	
15	4034 3514 02	REINFORCE PLATE		D	1	
16	4034 3501 01	DUCT		D	1	
17	4034 3515 01	SEAL		C	2	
18	4034 0755 00	TRANSFER ROLLER ASSY		A	1	
19	4021 4219 01	CONTACT		C	1	
20	1164 4222 01	PLATE SPRING		C	2	
21	1164 4206 02	BUSHING		C	2	
22	1164 4207 01	PRESSURE SPRING		C	2	
23	4034 3503 02	HOLDER		D	1	
24	4034 3517 01	CONTACT		C	1	
25	4011 0112 01	PWB-R2		C	1	
26	4034 3518 01	CONTACT		C	1	
27	1164 4202 04	NEUTRALIZING NEEDLE		D	1	
28	4163 5293 01	SCREW		C	1	
29	4021 4209 02	CONTACT		C	1	
30	4034 3512 02	HOLDER		D	1	
31	4034 3513 02	CONTACT		C	1	
32	4011 5858 01	SEAL		C	1	
33	4021 2307 01	LEVER		C	1	
34	4034 2301 01	LEVER		C	1	
35	4034 7310 01	LABEL		C	1	
36	9313 1300 31	FAN MOTOR		B	1	

FUSING SECTION

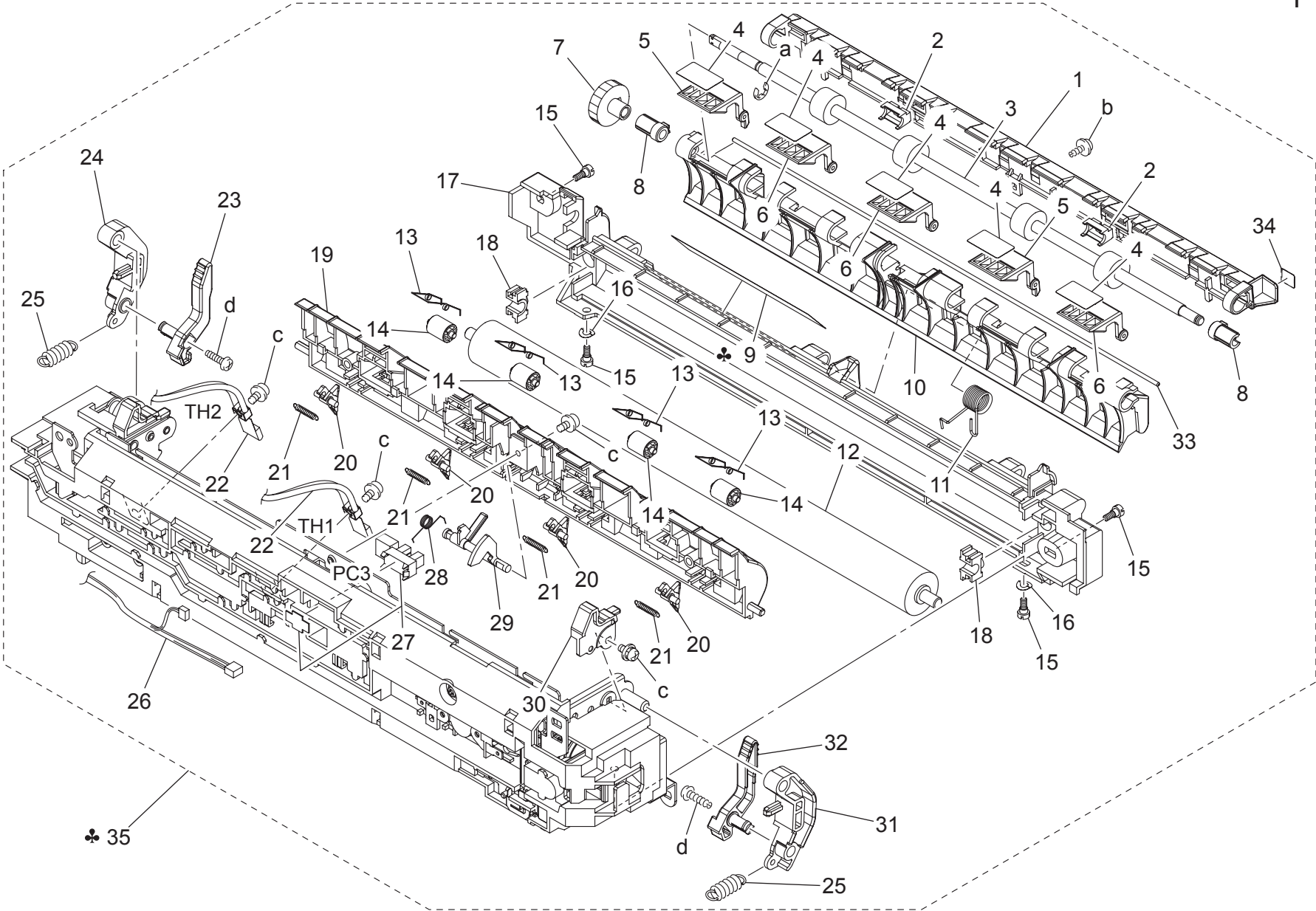

FUSING SECTION

Key	Part No.	Description	Destinations	Class	QTY	Standard parts
1	4034 5782 01	COVER		C	1	a-9721 0300 01 b-9739 0308 14 c-9646 0306 14 d-9732 0314 14
2	4034 5763 01	COLLAR		C	2	
3	4034 5751 01	ROLLER		C	1	
4	4011 5858 01	SEAL		C	5	
5	4034 5785 01	GUIDE		D	2	
6	4034 5784 01	GUIDE		D	3	
7	4034 5756 01	GEAR 21T		C	1	
8	4034 5753 01	BUSHING		C	2	
9	4034 7402 01	LABEL CAUTION	B,F1,G1,G2,H	C	1	
9	4034 7403 01	LABEL CAUTION	D,E,F2,G1,I,J,K	C	1	
9	4034 7404 01	LABEL CAUTION	C	C	1	
10	4034 5714 02	GUIDE		D	1	
11	4034 5715 01	TORSION SPRING		C	1	
12	4034 5702 01	FUSING ROLLER		C	1	
13	4034 5755 01	TORSION SPRING		C	4	
14	4034 5752 01	ROLL		C	4	
15	4021 5742 01	SHOULDER SCREW		C	4	
16	1164 5765 01	SPACER		D	2	
17	4034 5708 03	COVER		C	1	
18	4034 5711 01	BUSHING		C	2	
19	4034 5716 01	GUIDE		D	1	
20	4021 5720 02	SEPARATOR		A	4	
21	4034 5787 01	TENSION SPRING		C	4	
22	9372 2300 41	THERMISTOR		B	2	
23	4021 5726 03	LEVER		C	1	
24	4021 5733 01	LEVER		C	1	
25	4021 5727 01	TENSION SPRING		C	2	
26	4034 6827 01	WIRE HARNESS ASSY		D	1	
27	4537 0901 01	PHOTO INTERRUPTER		B	1	
28	4034 5723 01	TORSION SPRING		C	1	
29	4034 5722 01	ACTUATOR		D	1	
30	4034 5761 01	POSITIONING PLATE		D	1	
31	4021 5724 01	LEVER		C	1	
32	4021 5725 03	LEVER		C	1	
33	4034 5786 01	SHAFT		D	1	
34	4034 5741 01	LABEL		C	1	
35	4034 0751 00	FUSING UNIT 100/120V	B,F1,G2,H	A	1	
35	4034 0752 00	FUSING UNIT 200V	D,E,F2,G1,I,J,K	A	1	
35	4034 0754 00	FUSING UNIT 200V	C	A	1	

PAPER EXIT SECTION

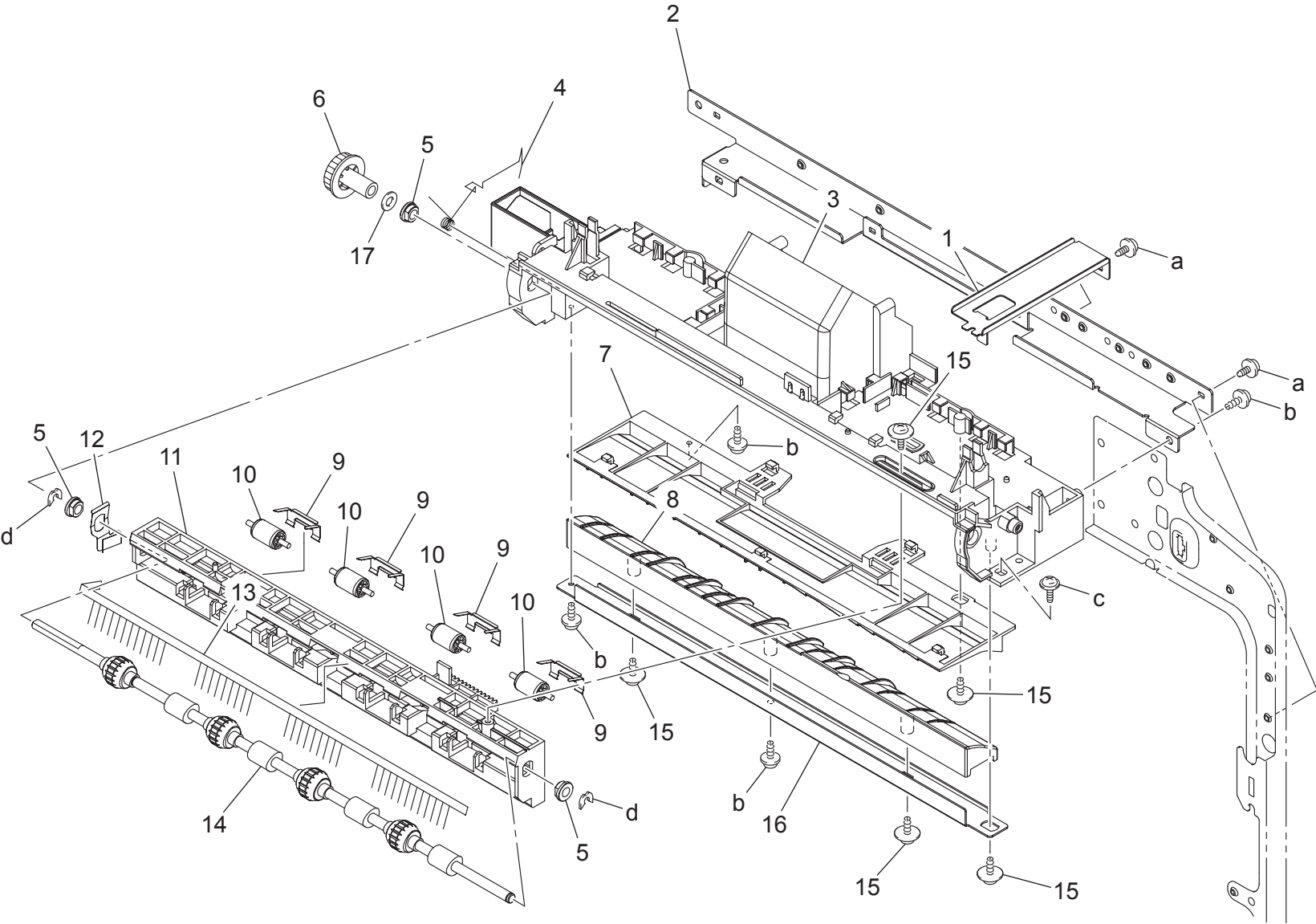

PAPER EXIT SECTION

Key	Part No.	Description	Destinations	Class	QTY	Standard parts
1	4021 5824 01	STOPPER		D	1	a-9735 0306 14 b-9739 0308 14 c-9739 0410 14 d-4425 3001 01
2	4034 2012 01	REINFORCE PLATE		D	1	
3	4034 5807 02	FRAME		D	1	
4	4021 5815 01	SPRING		C	1	
5	1159 1938 01	BUSHING		C	3	
6	4034 5806 02	GEAR		D	1	
7	4034 5802 01	GUIDE		D	1	
8	4034 5803 01	GUIDE		D	1	
9	4034 5808 01	PLATE SPRING		D	4	
10	4021 5802 01	ROLL		C	4	
11	4034 5805 02	FRAME		D	1	
12	4021 5819 01	SET PLATE		C	1	
13	4021 5814 01	NEUTRALIZING BRUSH		C	1	
14	4034 5801 01	ROLLER		C	1	
15	4163 5293 01	SCREW		C	5	
16	4034 5804 01	BRACKET		D	1	
17	4034 5809 01	WASHER		D	1	

DRIVE SECTION

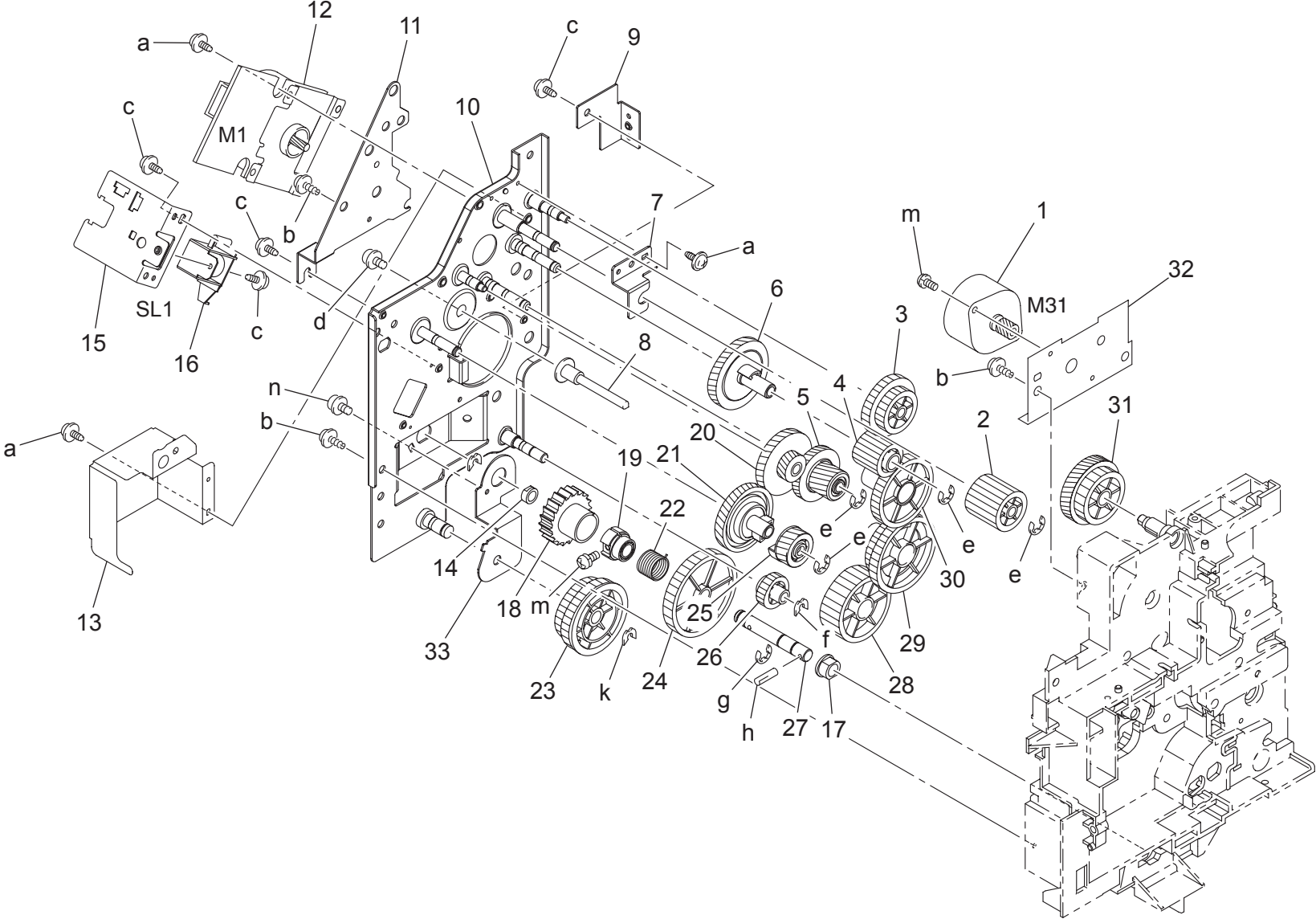

DRIVE SECTION

Key	Part No.	Description	Destinations	Class	QTY	Standard parts
1	9314 1300 11	MOTOR		B	1	a-9735 0306 14 b-9739 0408 14 c-9735 0308 14 d-9646 0308 14 e-9721 0400 01 f-4425 3001 01 g-9721 0600 01 h-9754 3022 08 k-1066 1151 01 m-9644 0308 14 n-9646 0305 14
2	4021 2512 01	GEAR 24T		C	1	
3	4021 2511 01	GEAR 26/49T		C	1	
4	4021 2510 01	GEAR 27T		C	1	
5	4021 2502 01	GEAR 22/62T		C	1	
6	4021 2505 01	GEAR 82T		C	1	
7	4021 2538 01	BRACKET		D	1	
8	4021 2519 01	SHAFT		D	1	
9	4034 2538 01	BRACKET		D	1	
10	4034 0201 02	DRIVING ASSY		D	1	
11	4034 2536 01	FRAME		D	1	
12	9314 2300 12	MOTOR		B	1	
13	4034 2550 01	BRACKET		D	1	
14	4658 3516 01	BUSHING		C	1	
15	4034 2540 01	BRACKET		D	1	
16	9321 2300 21	SOLENOID		C	1	
17	4021 2547 02	BUSHING		C	1	
18	4021 2540 01	RATCHET		C	1	
19	4021 2542 01	BUSHING		C	1	
20	4021 2501 01	GEAR 31/76T		C	1	
21	4021 2503 01	GEAR 77T		C	1	
22	4021 2541 01	TORSION SPRING		B	1	
23	4021 2517 01	GEAR 44/52T		C	1	
24	4021 2509 01	GEAR 70T		C	1	
25	4021 2504 01	GEAR 19T		C	1	
26	4034 2517 01	GEAR 26T		C	1	
27	4021 2533 03	SHAFT		D	1	
28	4034 2508 01	GEAR 56T		C	1	
29	4034 2507 01	GEAR 50/64T		C	1	
30	4034 2506 01	GEAR 58T		C	1	
31	4034 2515 03	GEAR 32/75T		C	1	
32	4034 2537 01	BRACKET		D	1	
33	4021 0204 01	BRACKET ASSY		D	1	

ELECTRICAL COMPONENTS

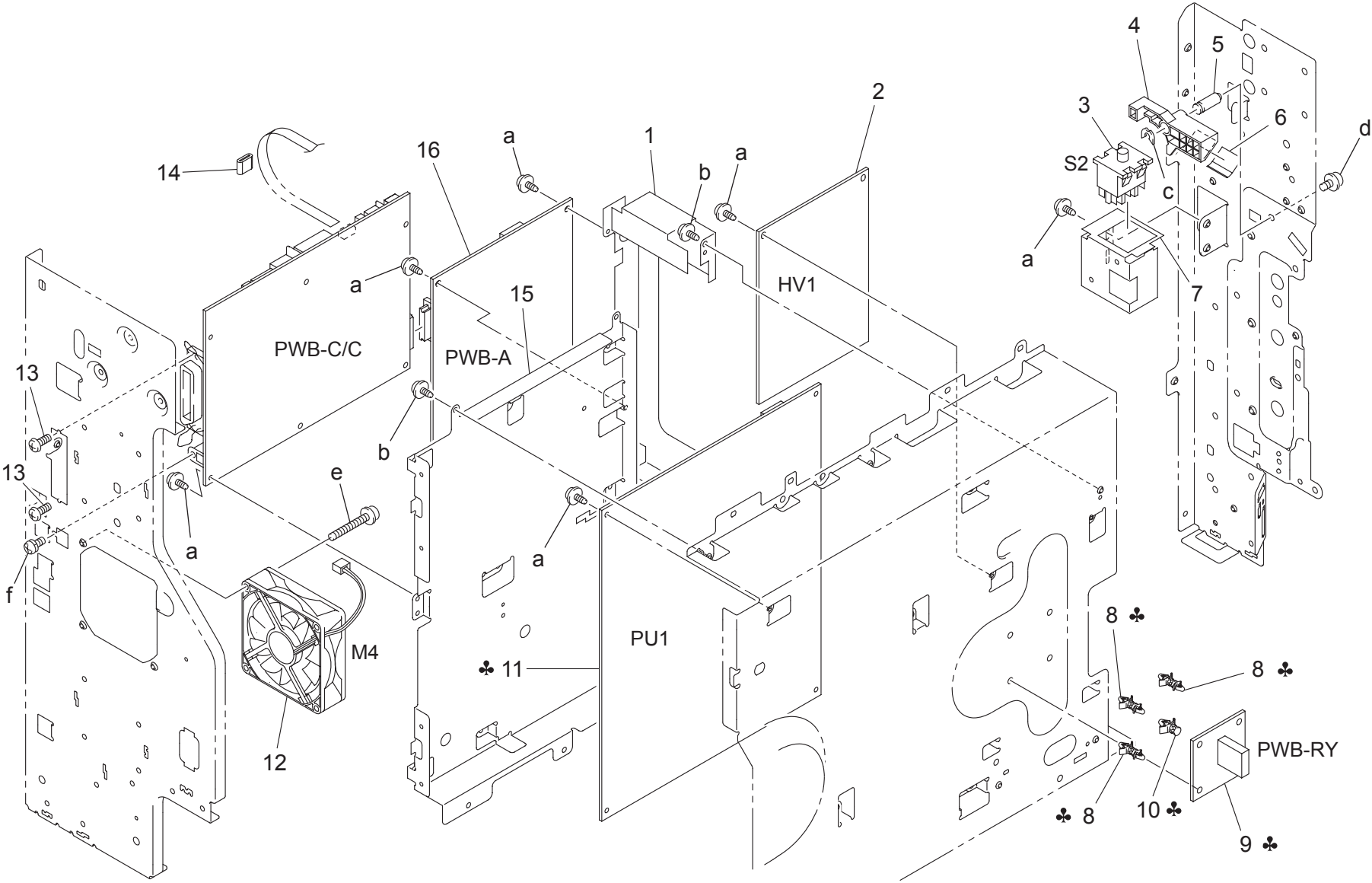

ELECTRICAL COMPONENTS

Key	Part No.	Description	Destinations	Class	QTY	Standard parts
1	4034 2202 01	BRACKET		D	1	a-9735 0306 14 b-9735 0308 14 c-1066 1151 01 d-9646 0308 14 e-9735 0330 14 f-9644 0308 14
2	4034 6205 03	HV TRANSFORMER		I	1	
3	9331 1810 11	MICRO SWITCH		C	1	
4	4034 2032 01	LEVER		C	1	
5	4021 2020 01	SHAFT		D	1	
6	4034 2033 01	INSTRUCTIONS		C	1	
7	4034 2016 02	BRACKET		D	1	
8	9384 1900 56	PWB SUPPORT 6.35H	C,D,E,F2,G1,I,J,K	D	3	
9	4028 0105 02	PWB-RY	C,D,E,F2,G1,I,J,K	I	1	
10	9384 1621 21	PWB SUPPORT 6.4H	C,D,E,F2,G1,I,J,K	D	1	
11	4034 6201 02	POWER SUPPLY	B,F1,G2,H	I	1	
11	4034 6202 02	POWER SUPPLY	C,D,E,F2,G1,I,J,K	I	1	
12	9313 1300 12	FAN MOTOR		C	1	
13	4034 2203 01	SCREW		D	2	
14	9326 1000 51	FERRITE CORE		D	1	
15	4034 2201 01	BRACKET		D	1	
16	4034 0101 06	PWB-A		I	1	

CASSETTE SECTION

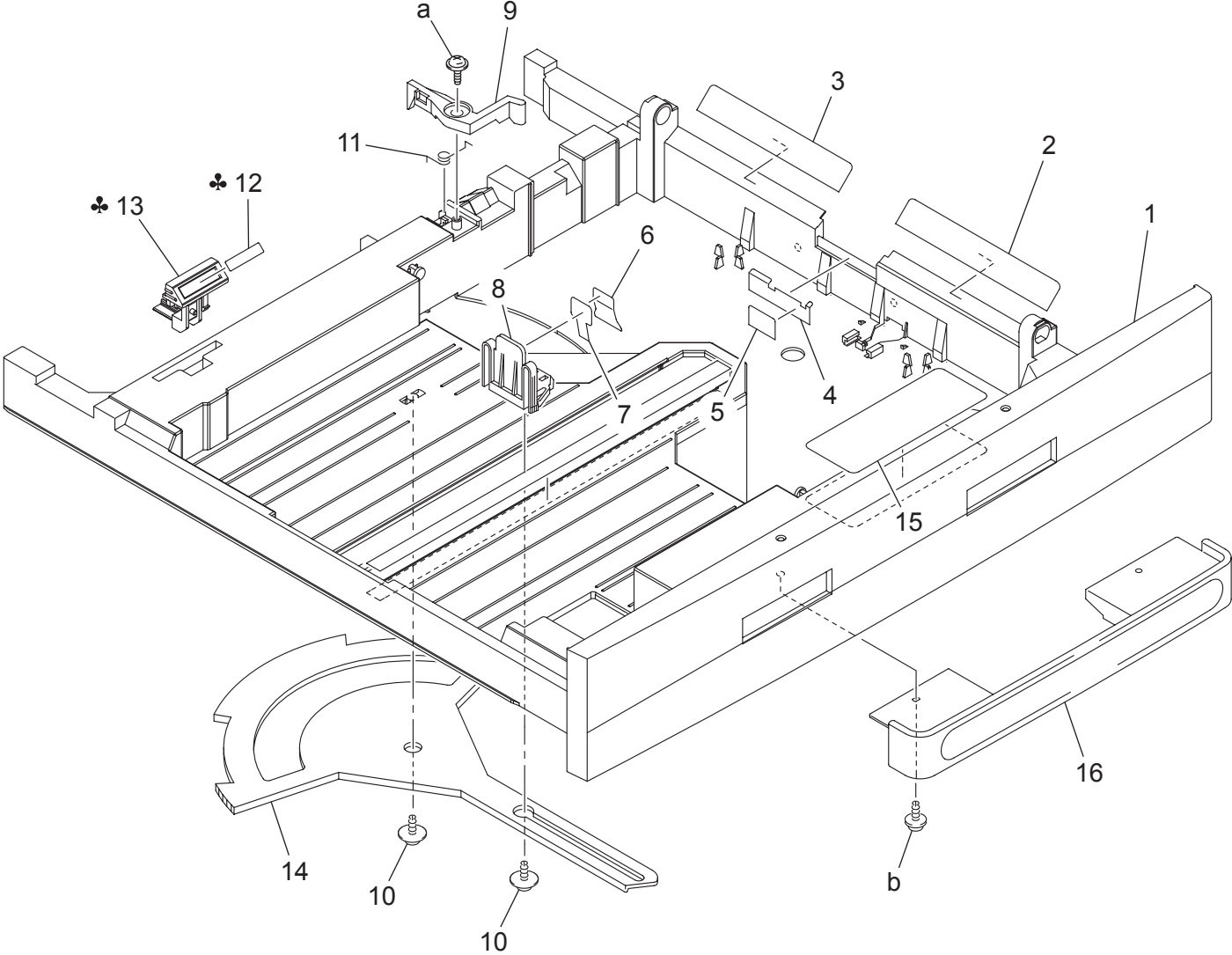

CASSETTE SECTION

Key	Part No.	Description	Destinations	Class	QTY	Standard parts
1	4021 3001 26	CASSETTE		D	1	a-4034 3005 01 b-9739 0308 14
2	4021 3020 01	GUIDE		C	1	
3	4021 3019 01	GUIDE		C	1	
4	4021 3031 13	GUIDE PLATE		D	1	
5	4021 3032 12	GUIDE		C	1	
6	4021 3035 02	GUIDE		C	1	
7	4021 3036 01	GUIDE		C	1	
8	4034 3014 01	REGULATING PLATE		C	1	
9	4011 3002 01	LEVER		C	1	
10	4163 5293 01	SCREW		C	2	
11	4011 3005 01	TORSION SPRING		C	1	
12	1151 7383 01	LABEL	D,E,F1,F2,G1,G2,I,K	C	1	
13	4034 3016 01	LEVER	D,E,F1,F2,G1,G2,I,K	C	1	
14	4686 3350 01	LEVER		C	1	
15	4034 7330 01	LABEL PAPER SET		D	1	
16	4034 3005 01	HANDLE		C	1	

CASSETTE SECTION

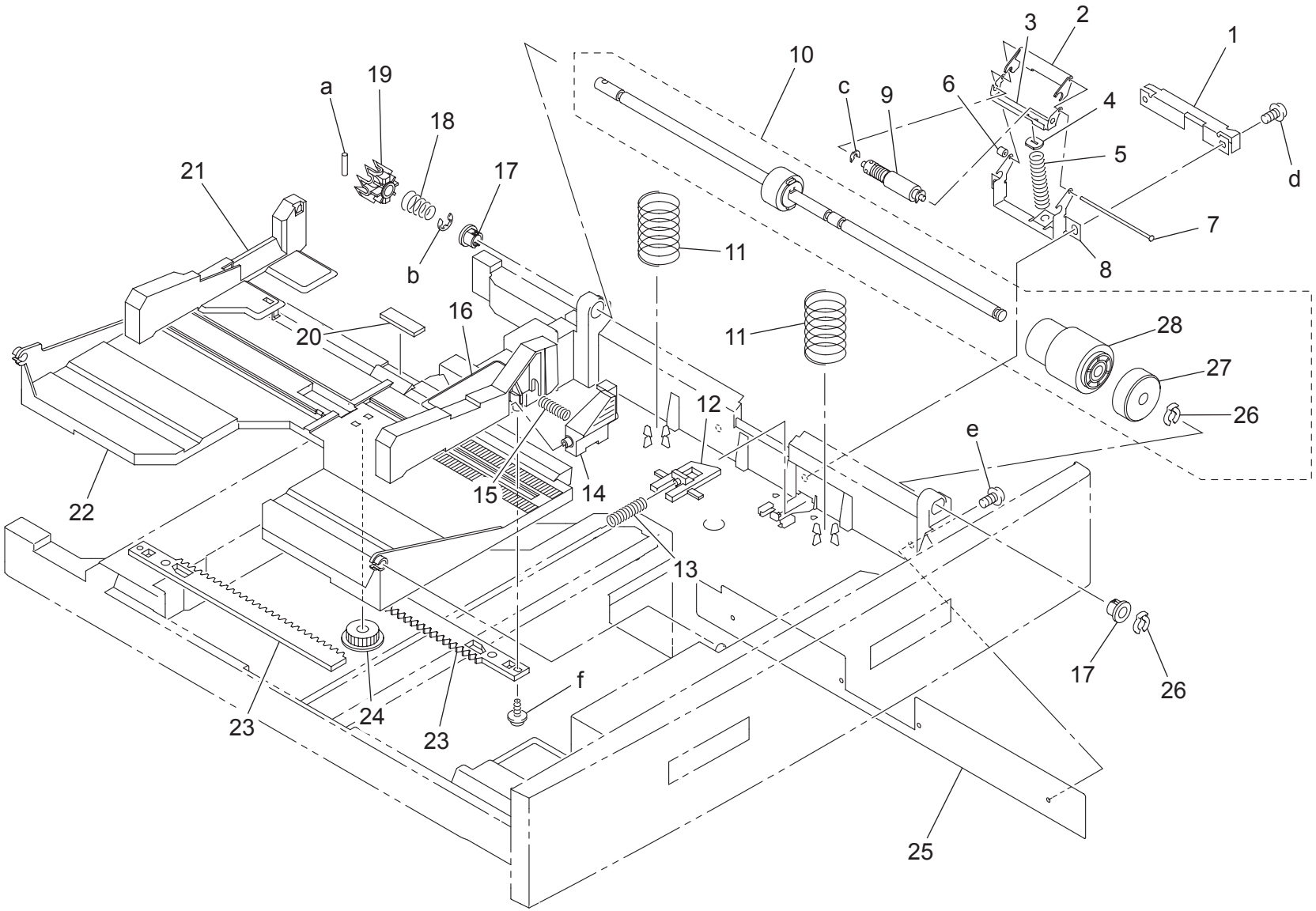

CASSETTE SECTION

Key	Part No.	Description	Destinations	Class	QTY	Standard parts
1	4021 3037 02	REGULATING PLATE		C	1	a-9752 3014 50 b-9721 0600 01 c-4425 3002 01 d-9654 0408 01 e-9654 0408 14 f-9739 0308 14
2	4658 3035 02	GUIDE		D	1	
3	4021 3013 02	HOLDER		D	1	
4	1144 3097 03	HOLDER		D	1	
5	4004 3006 03	PRESSURE SPRING		C	1	
6	4658 3047 01	COLLAR		C	1	
7	4658 3040 01	SHAFT		D	1	
8	4021 3014 02	BRACKET		D	1	
9	4034 0151 01	SEPARATION ROLLER		A	1	
10	4034 0757 00	TAKE-UP ROLLER ASSY		A	1	
11	1164 3047 02	PRESSURE SPRING		C	2	
12	1164 3061 01	LEVER		C	1	
13	1164 3062 01	PRESSURE SPRING		C	1	
14	4037 3210 01	LEVER		C	1	
15	4011 3011 01	PRESSURE SPRING		C	1	
16	4011 3008 01	REGULATING PLATE		C	1	
17	1164 3003 01	BUSHING		C	2	
18	1164 3005 02	PRESSURE SPRING		C	1	
19	1164 3004 03	PAWL		C	1	
20	1164 3064 01	FRICTION SHEET		C	1	
21	4011 3009 01	REGULATING PLATE		C	1	
22	4011 3007 03	LIFTING PLATE		D	1	
23	1164 3049 02	RACK		C	2	
24	1164 3045 01	GEAR 20T		C	1	
25	4021 3040 01	REINFORCE PLATE		D	1	
26	4658 3046 01	STOP RING		D	2	
27	4004 3005 01	COLLAR		C	1	
28	4034 3012 01	ROLLER		A	1	

PAPER FEEDER UNIT

CHINA ONLY

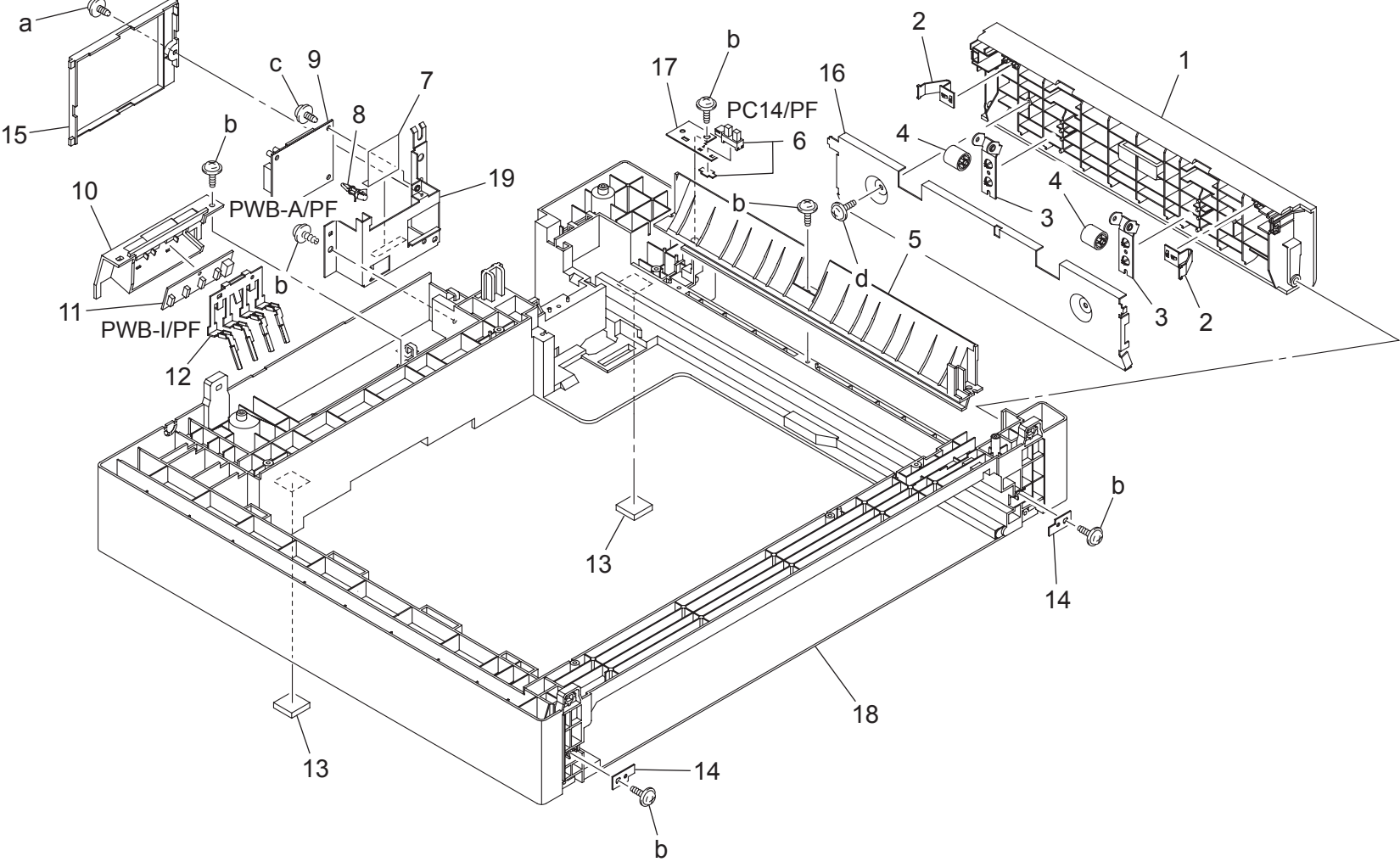

PAPER FEEDER UNIT

Key	Part No.	Description	Destinations	Class	QTY	Standard parts
1	4686 3372 01	DOOR	J	C	1	a-9654 0306 14 b-9739 0410 14 c-9735 0306 14 d-9739 0308 14
2	4686 3335 01	PLATE SPRING	J	C	2	
3	4686 3362 01	PLATE SPRING	J	C	2	
4	4686 3364 01	ROLL	J	C	2	
5	4686 3318 01	GUIDE	J	D	1	
6	4686 0903 01	PHOTO INTERRUPTER	J	B	1	
7	4686 3369 01	SHEET	J	C	1	
8	9384 1900 56	PWB SUPPORT 6.35H	J	D	1	
9	4686 0101 01	PWB-A	J	I	1	
10	4021 3004 01	HOLDER	J	D	1	
11	4037 0104 01	PWB-I	J	C	1	
12	1164 3020 03	LEVER	J	C	1	
13	4156 3826 01	RUBBER FOOT	J	D	2	
14	4686 3304 01	STOPPER	J	D	2	
15	4686 3373 01	COVER	J	C	1	
16	4686 3317 02	GUIDE PLATE	J	D	1	
17	4686 3319 01	BRACKET	J	D	1	
18	4686 3374 01	BASE FRAME	J	D	1	
19	4686 3306 03	BRACKET	J	D	1	

PAPER FEEDER UNIT

CHINA ONLY

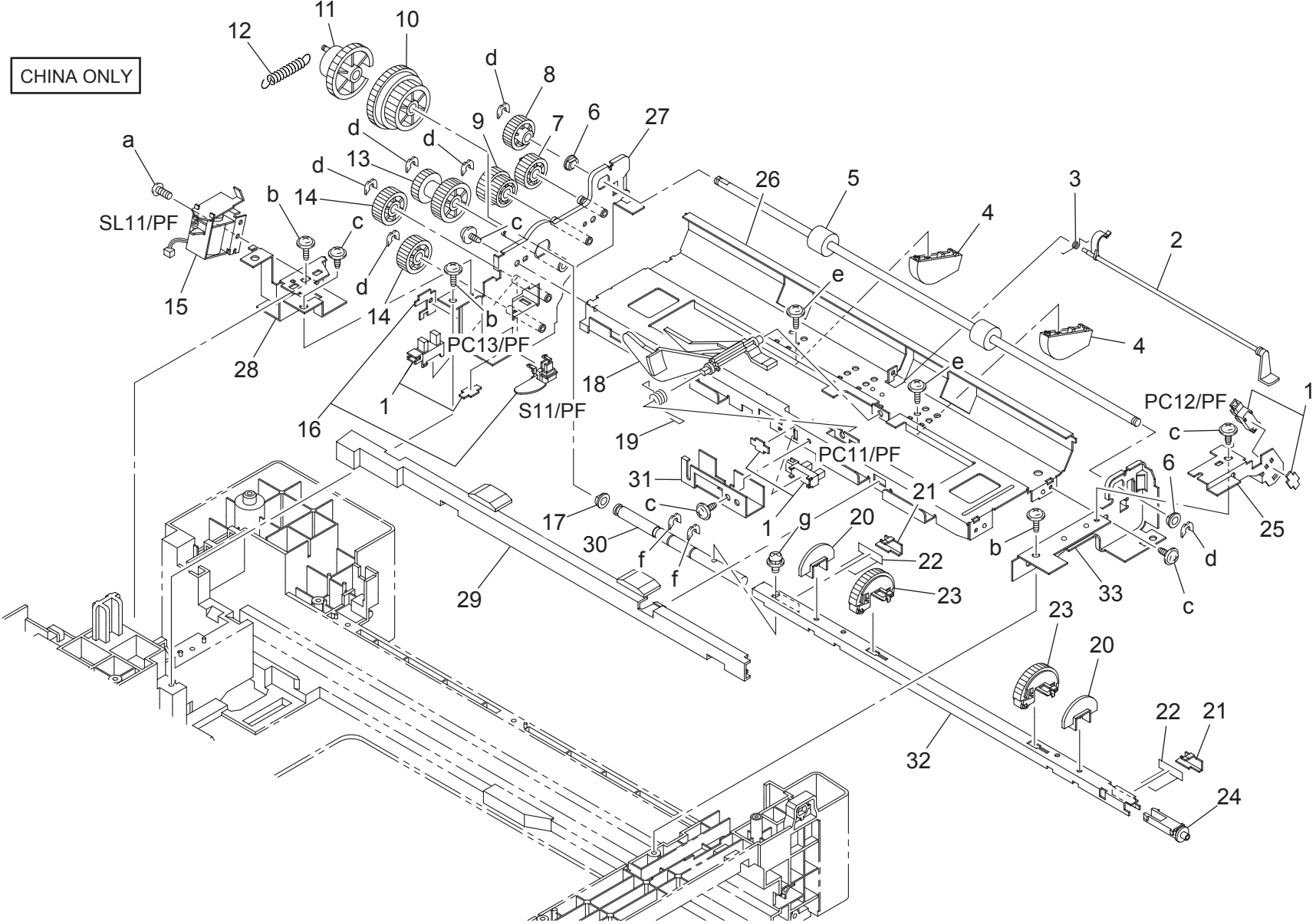

PAPER FEEDER UNIT

Key	Part No.	Description	Destinations	Class	QTY	Standard parts
1	4686 0903 01	PHOTO INTERRUPTER	J	B	3	a-9743 0306 14 b-9739 0410 14 c-9735 0306 14 d-4425 3001 01 e-9739 0308 14 f-1066 1151 01 g-9646 0308 14
2	4686 3310 01	ACTUATOR	J	C	1	
3	4686 3334 01	TORSION SPRING	J	C	1	
4	4686 3337 01	GUIDE	J	D	2	
5	4686 3360 01	ROLLER	J	C	1	
6	1200 3121 07	BUSHING	J	C	2	
7	4686 3351 01	GEAR 20T	J	C	1	
8	4686 3361 01	GEAR 18T	J	C	1	
9	4686 3343 01	GEAR 17/19T	J	C	1	
10	4686 3307 01	GEAR 29/38T	J	C	1	
11	4686 3358 01	GEAR	J	C	1	
12	4686 3359 01	TENSION SPRING	J	C	1	
13	4686 3308 01	GEAR 20/25T	J	C	1	
14	4686 3341 01	GEAR 22T	J	C	2	
15	9321 2100 22	SOLENOID	J	C	1	
16	4686 0902 01	PUSHBUTTON SWITCH	J	C	1	
17	4011 2504 01	BUSHING	J	C	1	
18	4686 3336 01	ACTUATOR	J	C	1	
19	4686 3353 01	TORSION SPRING	J	C	1	
20	4686 3312 01	COLLAR	J	C	2	
21	4686 3357 01	HOLD PLATE	J	D	2	
22	4686 3356 01	SEAL	J	C	2	
23	4686 3371 01	FEED ROLLER	J	A	2	
24	4686 3354 01	JOINT	J	D	1	
25	4686 3333 01	BRACKET	J	D	1	
26	4686 3355 01	GUIDE PLATE	J	D	1	
27	4686 0210 01	BRACKET ASSY	J	D	1	
28	4686 3316 01	BRACKET	J	D	1	
29	4658 3144 02	COVER	J	D	1	
30	4686 3313 01	SHAFT	J	D	1	
31	4498 3328 01	BRACKET	J	D	1	
32	4498 3333 02	AXLE PLATE	J	D	1	
33	4686 3314 01	FRAME	J	D	1	

PAPER FEEDER UNIT

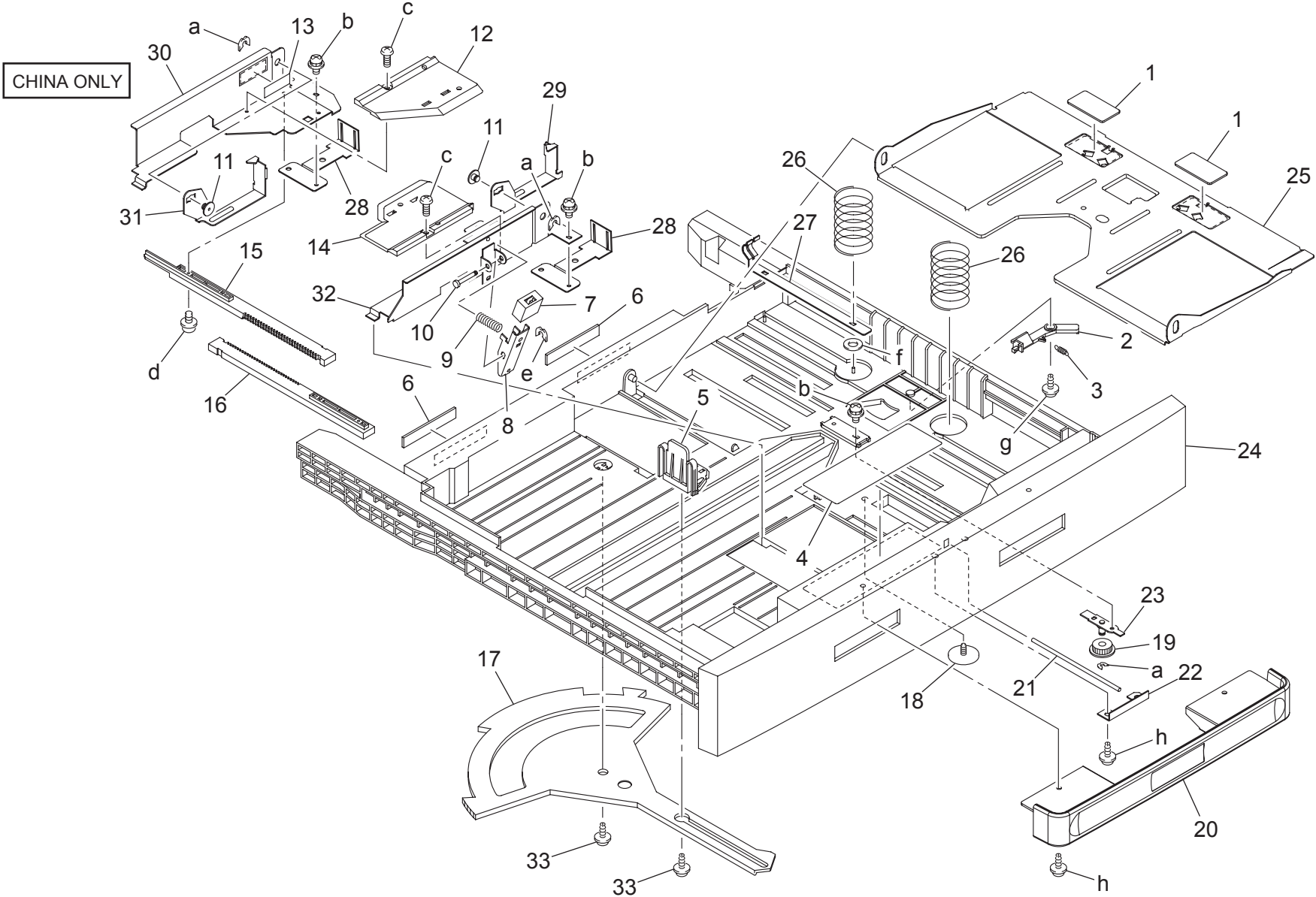

PAPER FEEDER UNIT

Key	Part No.	Description	Destinations	Class	QTY	Standard parts
1	4686 3365 01	FRICION SHEET	J	C	2	a-4425 3001 01 b-9646 0306 14 c-9743 0306 14 d-9646 0310 14 e-4425 3002 01 f-9716 0400 01 g-9739 0308 14 h-9739 0408 14
2	4686 3328 01	LEVER	J	C	1	
3	4498 3404 01	TENSION SPRING	J	C	1	
4	4686 7315 01	LABEL PAPER SET	J	D	1	
5	4034 3014 01	REGULATING PLATE	J	C	1	
6	4498 3833 01	FRICION SHEET	J	C	2	
7	4686 3375 01	KNOB	J	C	1	
8	4686 3346 01	LEVER	J	C	1	
9	4686 3347 01	PRESSURE SPRING	J	C	1	
10	4498 3826 01	SHAFT	J	D	1	
11	4498 3345 04	HOLD PLATE	J	D	2	
12	4686 3322 01	COVER	J	D	1	
13	4002 7306 01	LABEL CARRYING CAPACITY	J	D	1	
14	4686 3321 01	COVER	J	D	1	
15	4686 3326 03	RACK	J	D	1	
16	4686 3325 02	RACK	J	D	1	
17	4686 3350 01	LEVER	J	C	1	
18	4109 2003 01	SHOULDER SCREW	J	C	1	
19	4686 3329 01	GEAR 14T	J	C	1	
20	4034 3005 01	HANDLE	J	C	1	
21	4686 3348 02	SHAFT	J	D	1	
22	4686 3349 01	BRACKET	J	D	1	
23	4686 0211 01	BRACKET ASSY	J	D	1	
24	4686 3320 14	CASSETTE	J	D	1	
25	4686 3327 01	LIFTING PLATE	J	D	1	
26	4686 3366 01	PRESSURE SPRING	J	C	2	
27	4686 3330 01	PLATE SPRING	J	D	1	
28	4686 3367 01	REINFORCE PLATE	J	D	2	
29	0996 3022 01	PAWL	J	D	1	
30	4686 3324 02	REGULATING PLATE	J	D	1	
31	0996 3023 01	PAWL	J	D	1	
32	4686 3323 02	REGULATING PLATE	J	D	1	
33	4163 5293 01	SCREW	J	C	2	

WIRING

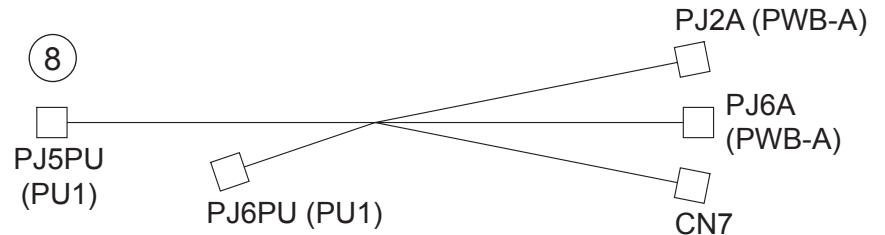
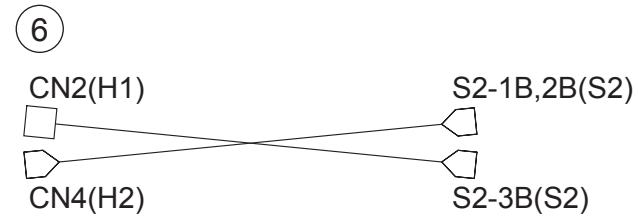
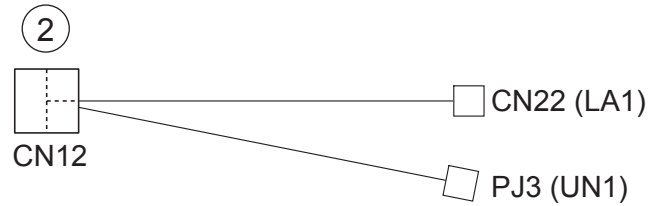

WIRING

Key	Part No.	Description	Destinations	Class	QTY	Standard parts
1	4021 6818 01	WIRE HARNESS ASSY		D	1	
2	4021 6820 01	WIRE HARNESS ASSY		D	1	
3	4021 6831 01	WIRE HARNESS ASSY		D	1	
4	4021 6844 01	WIRE HARNESS ASSY		D	1	
5	4034 6805 01	WIRE HARNESS ASSY		D	1	
6	4034 6806 01	WIRE HARNESS ASSY		D	1	
7	4034 6810 02	WIRE HARNESS ASSY		D	1	
8	4034 6811 01	WIRE HARNESS ASSY		D	1	
9	4034 6812 01	WIRE HARNESS ASSY		D	1	
10	4034 6813 01	WIRE HARNESS ASSY		D	1	

WIRING

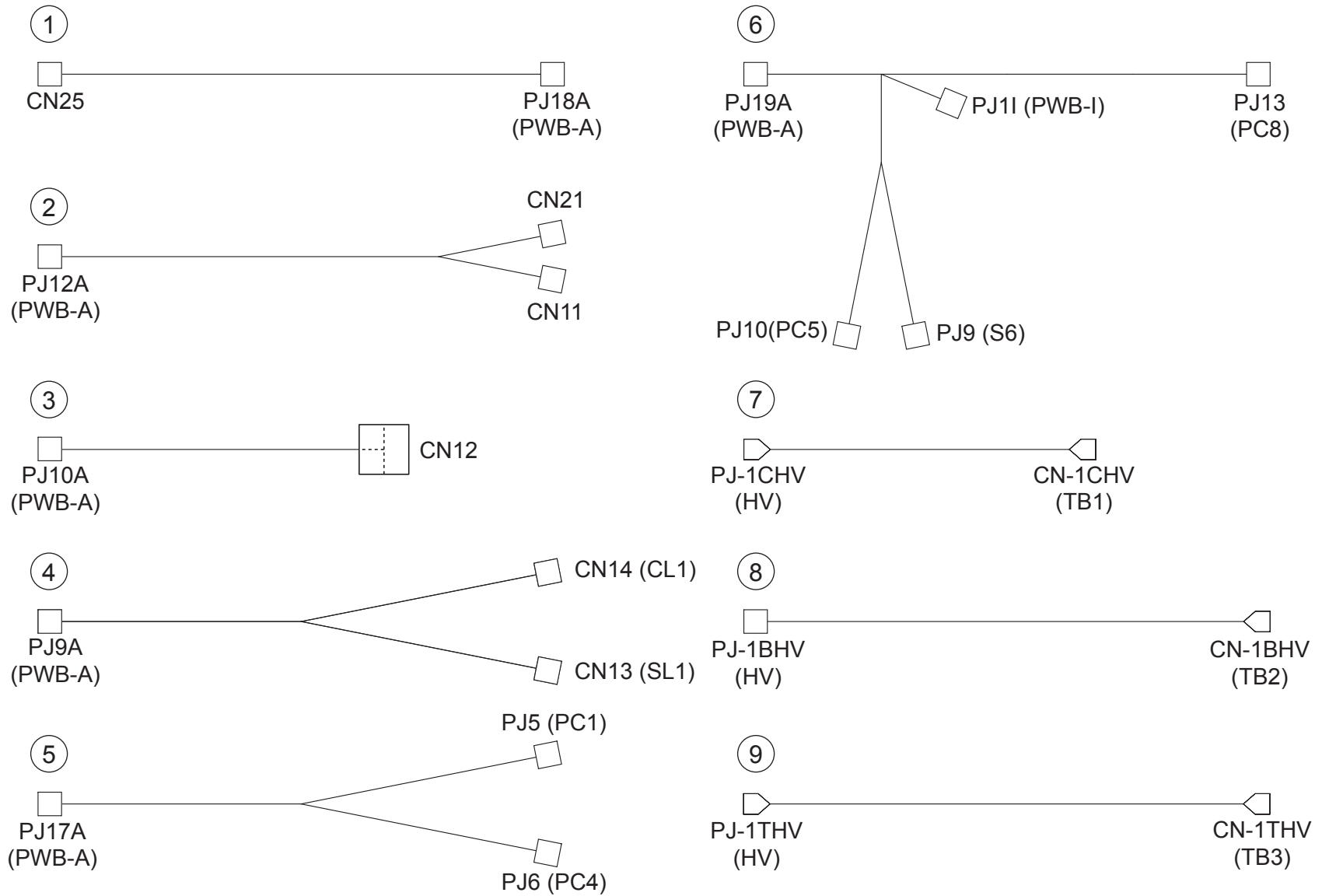

WIRING

Key	Part No.	Description	Destinations	Class	QTY	Standard parts
1	4034 6816 01	WIRE HARNESS ASSY		D	1	
2	4034 6817 01	WIRE HARNESS ASSY		D	1	
3	4034 6819 01	WIRE HARNESS ASSY		D	1	
4	4034 6821 01	WIRE HARNESS ASSY		D	1	
5	4034 6822 01	WIRE HARNESS ASSY		D	1	
6	4034 6830 01	WIRE HARNESS ASSY		D	1	
7	4034 6834 01	WIRE HARNESS ASSY		D	1	
8	4034 6835 01	WIRE HARNESS ASSY		D	1	
9	4034 6836 01	WIRE HARNESS ASSY		D	1	

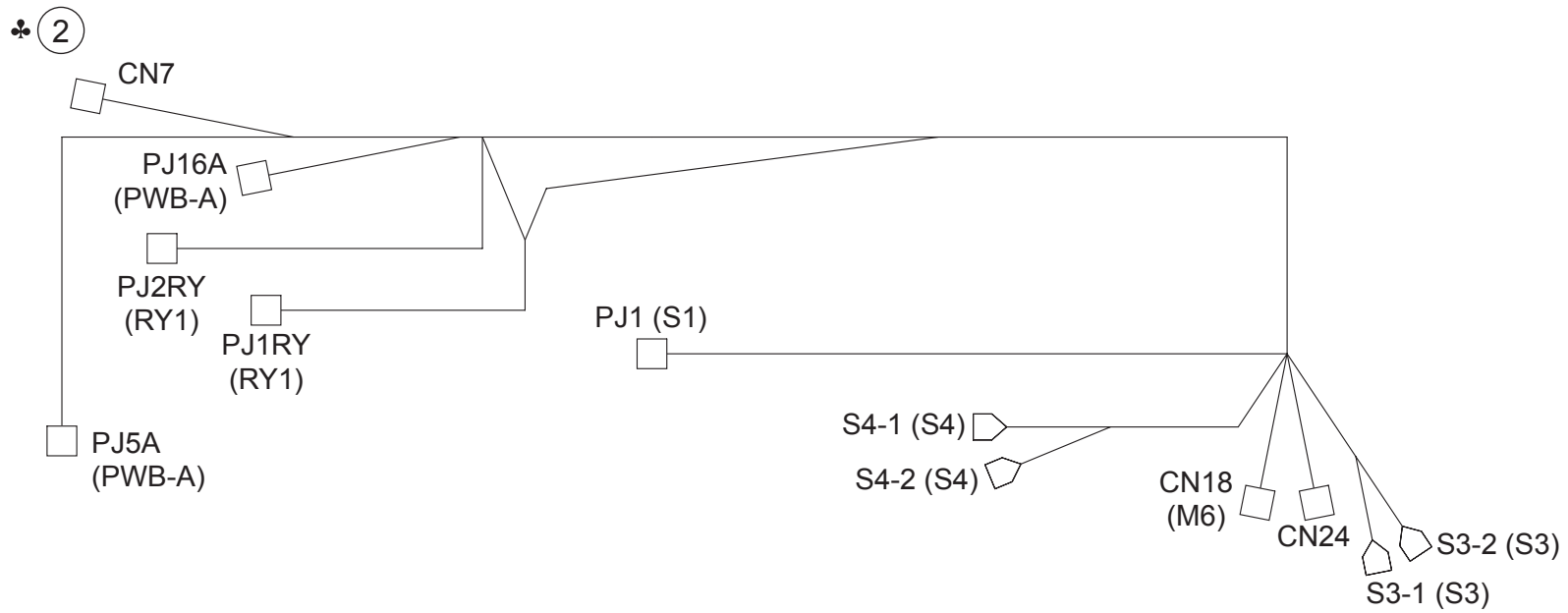
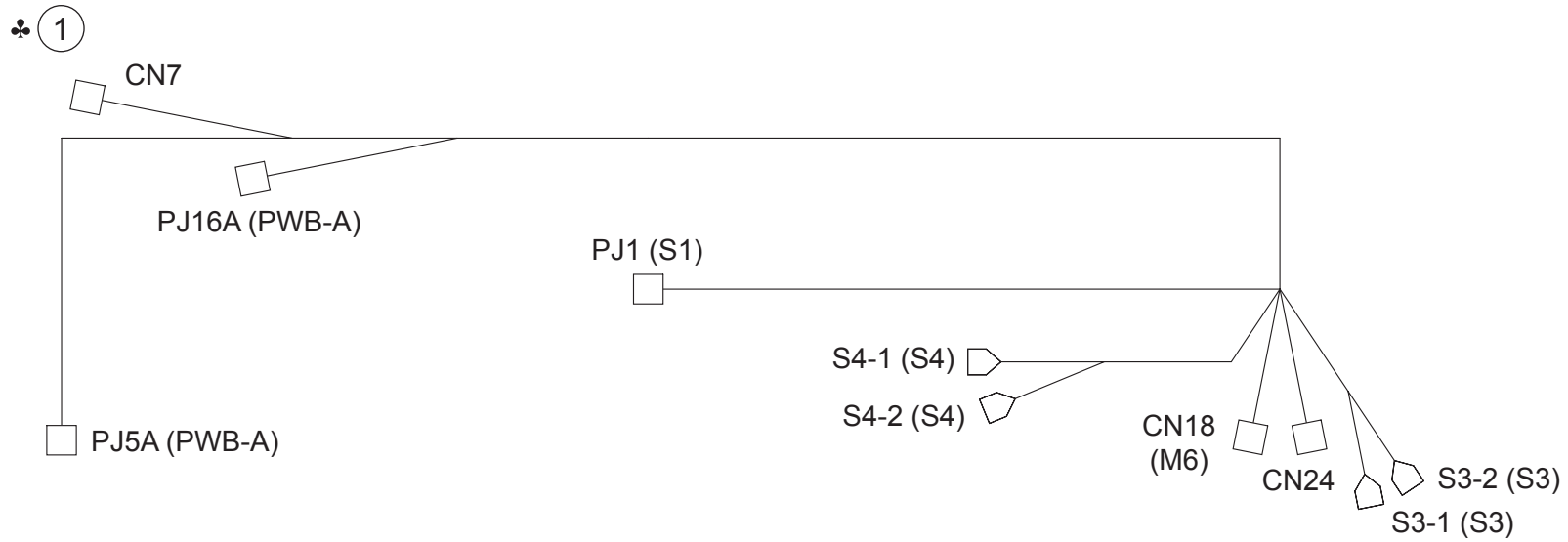

WIRING

Key	Part No.	Description	Destinations	Class	QTY	Standard parts
1	4034 6815 01	WIRE HARNESS ASSY	B,F1,G2,H	D	1	
2	4034 6880 01	WIRE HARNESS ASSY	C,D,E,F2,G1,I,J,K	D	1	

WIRING

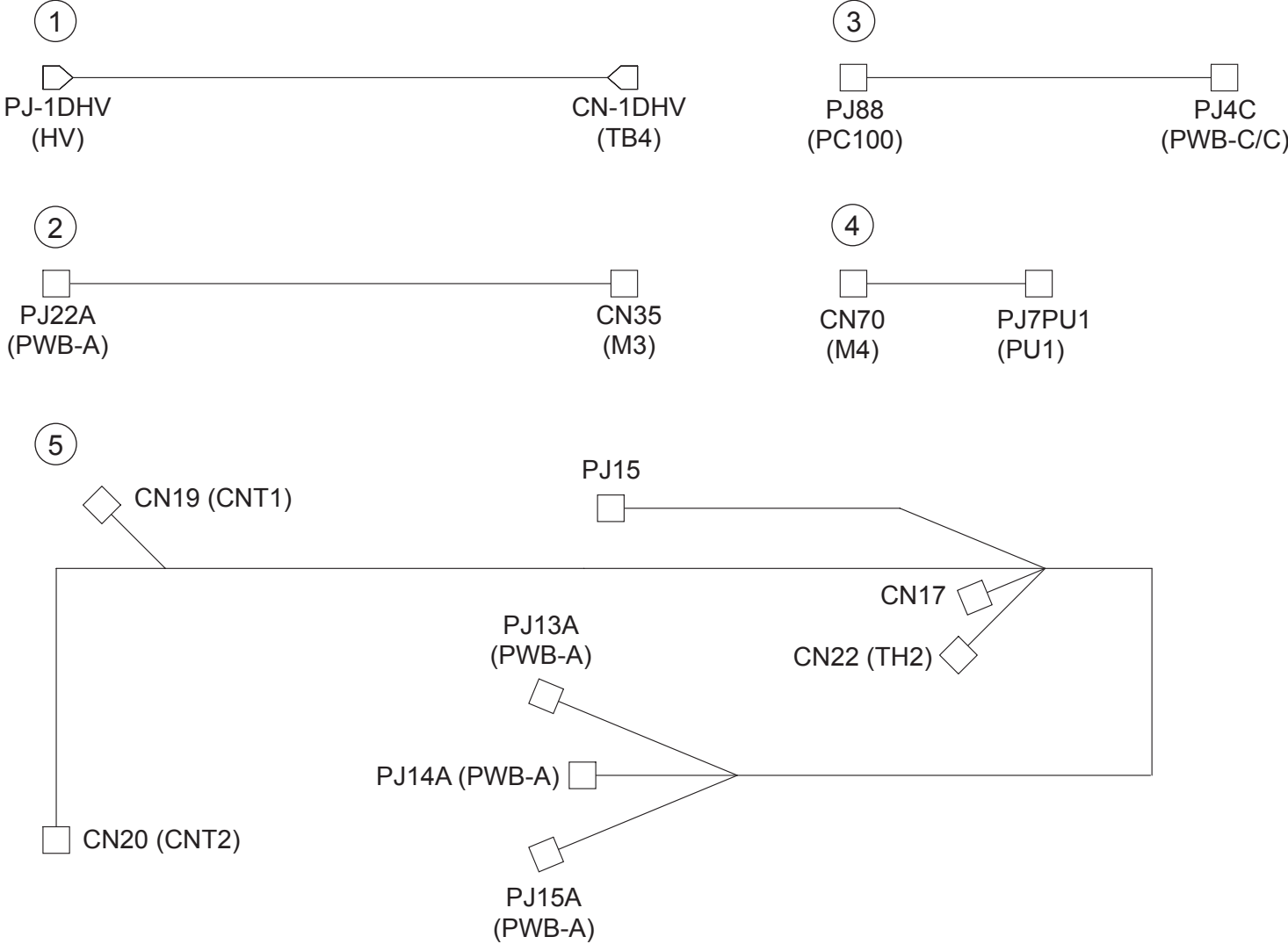

WIRING

Key	Part No.	Description	Destinations	Class	QTY	Standard parts
1	4034 6837 01	WIRE HARNESS ASSY		C	1	
2	4034 6840 01	WIRE HARNESS ASSY		D	1	
3	4034 6860 01	WIRE HARNESS ASSY		D	1	
4	4034 6881 02	WIRE HARNESS ASSY		D	1	
5	4034 6825 02	WIRE HARNESS ASSY		D	1	

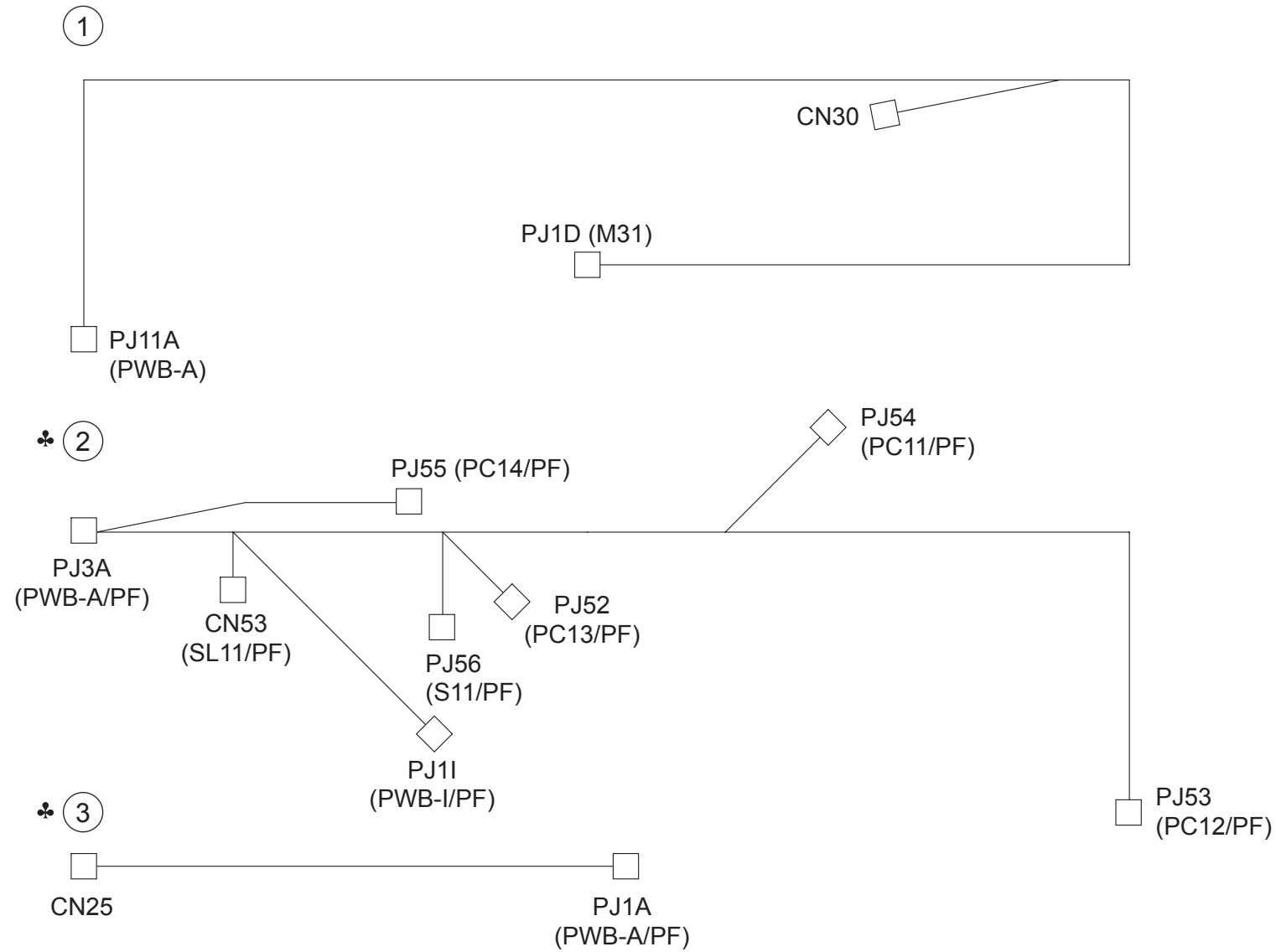

WIRING

Key	Part No.	Description	Destinations	Class	QTY	Standard parts
1	4034 6847 01	WIRE HARNESS ASSY		D	1	
2	4686 6801 02	WIRE HARNESS ASSY	J	D	1	
3	4686 6802 04	WIRE HARNESS ASSY	J	D	1	

WIRING ACCESSORIES AND JIGS

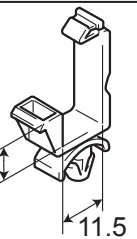
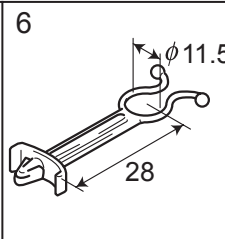
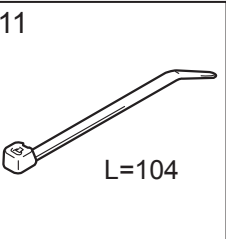
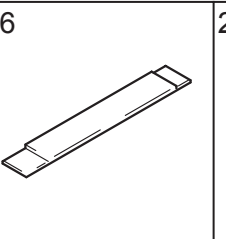
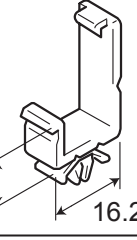
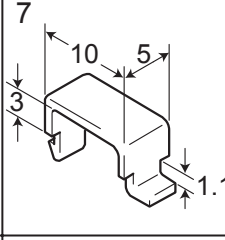
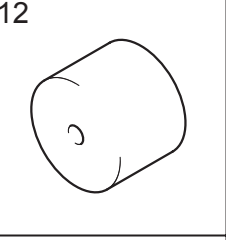
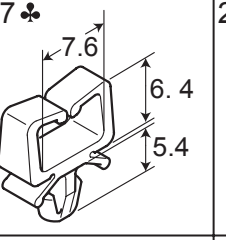
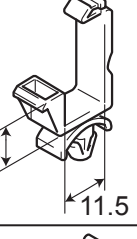
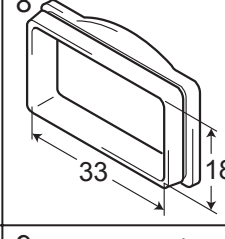
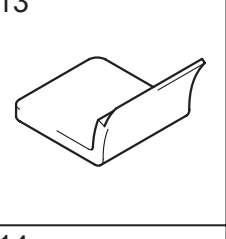
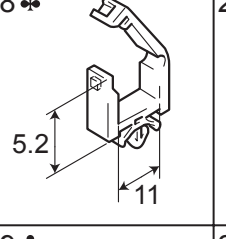
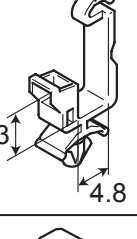
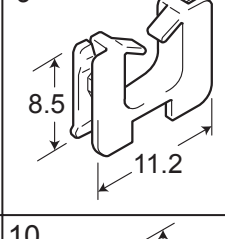
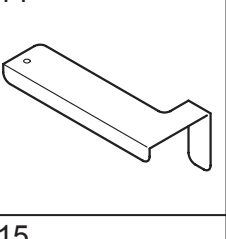
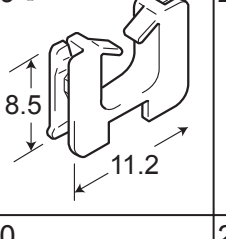
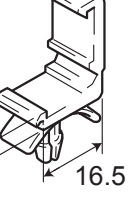
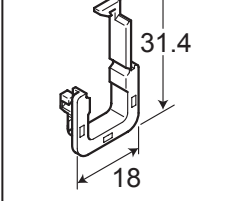
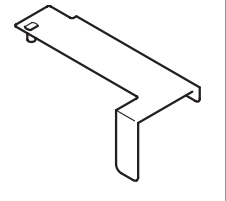
1 	6 	11 	16 	21	26	31	36
2 	7 	12 	17♣ 	22	27	32	37
3 	8 	13 	18♣ 	23	28	33	38
4♣ 	9 	14 	19♣ 	24	29	34	39
5 	10 	15 	20	25	30	35	40

WIRING ACCESSORIES AND JIGS

Key	Part No.	Description	Destinations	Class	QTY	Standard parts
1	9384 1000 51	WIRING SADDLE		D	4	
2	9384 1310 91	WIRING SADDLE 18.5H		D	15	
3	9384 1921 11	WIRING SADDLE 9.2H		D	16	
4	9384 1100 91	WIRING SADDLE	C,D,E,F2,G1,I,J,K	D	19	
4	9384 1100 91	WIRING SADDLE	B,F1,G2,H	D	18	
5	9384 1900 54	WIRING SADDLE 23.0H		D	1	
6	9384 1911 11	SO CLIP		D	5	
7	1053 4812 01	CORD CLAMP		D	2	
8	1038 4006 01	INSULATING MEMBER		D	1	
9	9384 2010 21	EDGE COVER 8.5H		D	8	
10	9384 2910 31	EDGE COVER		D	3	
11	9384 1311 11	CABLE TIE 104L		D	1	
12	4021 7903 01	JIG		S	2	
13	4021 7904 01	JIG		S	2	
14	4034 7901 01	JIG		S	1	
15	4034 0760 01	POSITIONING PLATE ASSY		S	1	
16	1144 7910 01	JIG TRANSFER ADJUSTING		S	1	
17	9384 1310 81	WIRING SADDLE 6.4H	J	D	2	
18	9384 1310 11	WIRING SADDLE 5.2H	J	D	1	
19	9384 2010 21	EDGE COVER 8.5H	J	D	4	

ACCESSORY PARTS

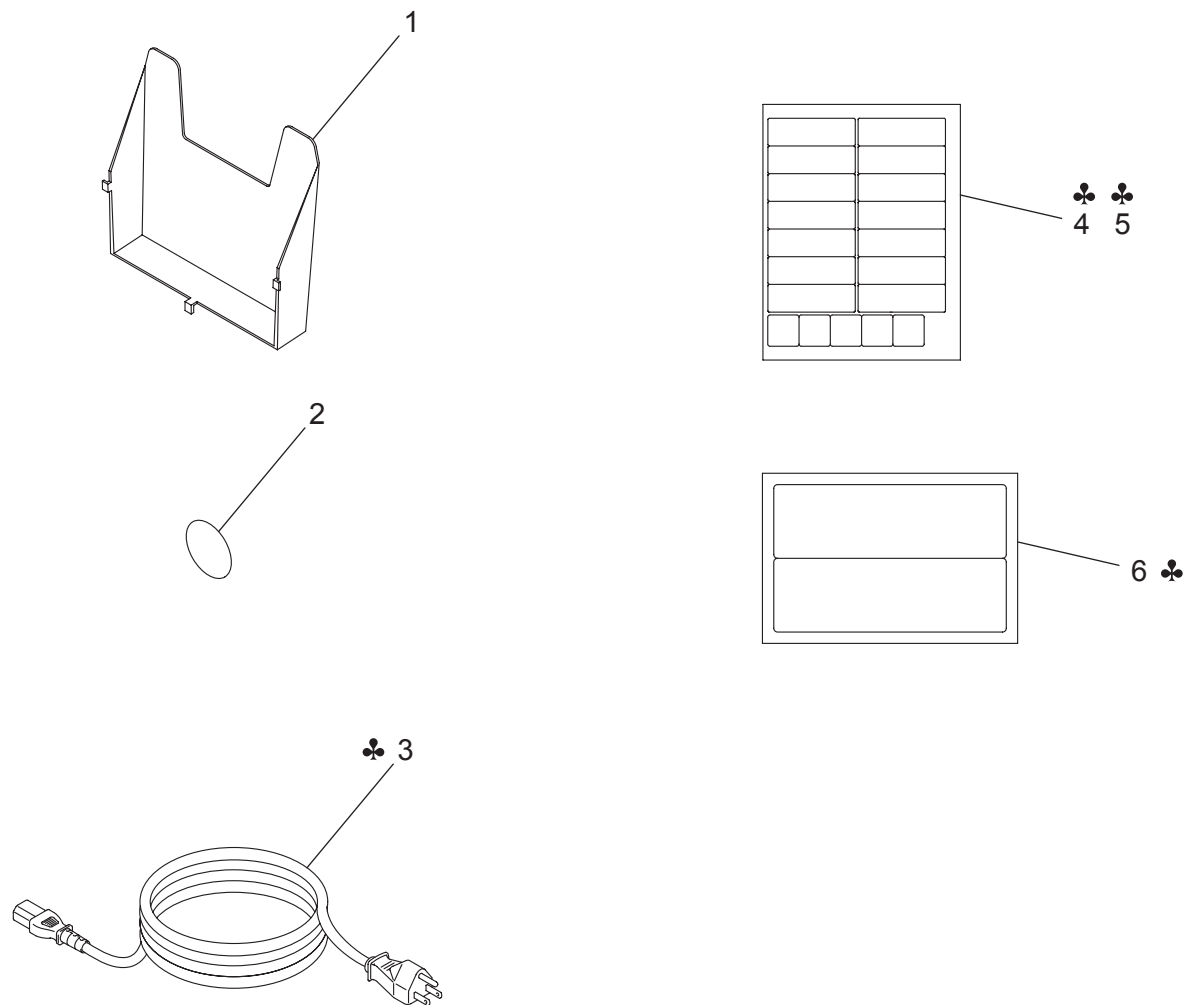

ACCESSORY PARTS

Key	Part No.	Description	Destinations	Class	QTY	Standard parts
1	4034 7507 01	HOLDER		C	1	
2	4034 7603 01	SEAL		C	1	
3	9381 4101 31	POWER CORD	B,G2	C	1	
3	9381 4300 31	POWER CORD	J	C	1	
3	9381 4300 41	POWER CORD	D,E,F2,G1,I,K	C	1	
3	9381 4300 91	POWER CORD	H	C	1	
4	4011 7313 01	LABEL SIZE METRIC	C,D,E,F1,F2,G1,G2,I,K,H	C	1	
4	4021 7319 01	LABEL SIZE	J	C	1	
5	4011 7314 01	LABEL SIZE INCH	B,D,E,F1,F2,G1,G2,I,K	C	1	
6	4658 7305 01	LABEL PAPER SIZE	J	C	1	

MAINTENANCE LIST

● The items with no Page/Key numbers are not handled as spare parts.

No.	Section	PM Parts Description	Maintenance Cycle (K=1,000)		Parts No.	Destinations	Page/Key	Note
			QTY	Replace				
1	Paper Take-up Section	Feed Roller	1	150K	4034-3012-01	-	P21-28	
2		Separation Roller Assy	1	150K	4034-0151-01	-	P21-09	
3	Transport Section	Paper Dust Remover	1	40K	4034-0756-00	-	P8-21	
4	Imaging Unit Section	PC Drum	1	40K	-	-	-	
5		Ozone Filter	1	150K	1156-4118-02	-	P14-20	
6		PC Drum Charge Corona Assy	1	40K	4021-0306-02	-	P12-27	
7		Cleaning Blade	1	40K	4034-5622-01	-	P14-22	
8		Developer	1	40K	-	-	-	
9	Image Transfer Section	Image Transfer Roller Assy	1	150K	4034-0755-00	-	P15-18	
10	Fusing Section	Fusing Unit	1	150K	4034-0751-00	B,F1,G2,H	P16-35	
11		Fusing Unit	1	150K	4034-0752-00	D,E,F2,G1,I,J,K	P16-35	
12		Fusing Unit	1	50K	4034-0754-00	C	P16-35	
13	Paper Take-up Section (Paper	Feed Roller	2	150K	4686-3371-01	J	P23-23	

DESTINATION

Destination No.		Destinations		V	Hz	Model No.
A	A1	JAPAN		100	50/60	
	A2	JAPAN		200	50/60	
B		USA, CANADA		120	60	4034-301
C		EUROPEAN TYPE		220-240	50/60	4034-201/ 4034-202
D	D1	S.E ASIA TYPE	THAILAND, SRI LANKA, SINGAPORE, MALAYSIA, HONG KONG, PAKISTAN, INDIA, BANGLADESH, INDONESIA	220-240	50/60	4034-203
	D3	OCEANIA TYPE	AUSTRALIA, NEW ZEALAND	220-240	50/60	4034-203
E		PHILIPPINES		220-240	50/60	4034-203
F	F1	SAUDI ARABIA		127	60	4034-304
	F2	SAUDI ARABIA		220-240	50/60	4034-203
G	G1	C.S AMERICA		220-240	50/60	4034-203
	G2	C.S AMERICA		120	60	4034-302/ 4034-304
H		TAIWAN		110	60	4034-303
I		JORDAN, LEBANON, SYRIA, SOUTH AFRICA, IRAQ, IRAN, N.YEMEN, CAMEROON, UAE, BAHRAIN, OMAN, QATAR, KUWAIT, KENYA, TUNISIA, IVORY COAST, MOROCCO		220-240	50/60	4034-203
J		CHINA		220-240	50/60	4034-204
K		KOREA		220-240	50/60	4034-203